



**WORLD TAEKWONDO FEDERATION
COMPETITION RULES & INTERPRETATION**

In force as of January 1, 2015

Enacted: May 28, 1973

Amended: Oct. 1, 1977

Amended: Feb. 23, 1982

Amended: Oct. 19, 1983

Amended: June 1, 1986

Amended: Oct. 7, 1989

Amended: Oct. 28, 1991

Amended: Aug. 17, 1993

Amended: Nov. 18, 1997

Amended: Oct. 31, 2001

Amended: Sep. 23, 2003

Amended: April 12, 2005

Amended: February 13, 2009

Amended: March 2, 2010

Amended: October 7, 2010

Amended: April 30, 2011

Amended: October 4, 2011

Amended: April 3, 2012

Amended: December 26, 2012

Amended: July 14, 2013

Amended: March 19, 2014

Amended: October 30, 2014

**World Taekwondo Federation
Competition Rules & Interpretation
Table of Contents**

Article 1. Purpose	1
Article 2. Application	1
Article 3. Competition Area	2
Article 4. Contestant	6
Article 5. Weight Division	8
Article 6. Classification and methods of competition	10
Article 7. Duration of Contest	11
Article 8. Drawing of Lots	12
Article 9. Weigh-in	12
Article 10. Procedure of the Contest	13
Article 11. Permitted techniques and area	14
Article 12. Valid points	14
Article 13. Scoring and publication	15
Article 14. Prohibited acts and penalties	15
Article 15. Golden Point and decision of superiority	19
Article 16. Decisions	20
Article 17. Knock down	22
Article 18. Procedure in the event of Knock down	22
Article 19. Procedure of suspending the match	24
Article 20. Technical Officials	25
Article 21. Instant Video Replay	27
Article 22. Para-Taekwondo	29
Article 23. Deaf-Taekwondo	31
Article 24. Sanctions	31
Article 25. Other matters not specified in the Rules	33
Referee's Hand Signals	34

Article 1 Purpose

- 1 The purpose of the Competition Rules is to provide standardized rules for all levels of Championships organized or/and promoted by the World Taekwondo Federation, WTF Continental Unions, or/and WTF Member National Associations; the Competition Rules are intended to ensure that all matters related to competitions are conducted in a fair and orderly manner.

(Interpretation)

The objective of Article 1 is to ensure the standardization of all Taekwondo competition worldwide. Any competition not following the fundamental principles of these rules cannot be recognized as Taekwondo competition.

Article 2 Application

- 1 The Competition Rules shall apply to all the competitions to be promoted and/or organized by the WTF, each Continental Union and member National Association. However, any member National Association wishing to modify some or any part of the Competition Rules must first gain the prior approval of the WTF. In the case that a Continental Union and/or a Member National Association violates WTF Competition Rules without prior approval of the WTF, the WTF may exercise its discretion to disapprove or revoke its approval of the concerned international tournament. In addition, the WTF may take further disciplinary actions to the pertinent Continental Union or Member National Association.
- 2 All competitions promoted, organized, or sanctioned by the WTF shall observe the WTF Statutes, the Bylaws of Dispute Resolution and Disciplinary Action, and all other pertinent rules and regulations.
- 3 All competitions promoted, organized, or sanctioned by the WTF shall abide by the WTF Medical Code and the WTF Anti-Doping Rules.

(Explanation#1)

First gain the approval: Any organization desiring to make a change in any portion of the existing rules must submit to the WTF the contents of the desired amendment along with the reasons for the desired changes. Approval for any changes in these rules must be received from the WTF at least one month prior to the scheduled competition. WTF can apply Competition Rules with modifications in its promoted Championships with the decision of the Technical Delegate after approval of the President.

Article 3 Competition Area

- 1 The Contest Area shall have a flat surface without any obstructing projections, and be covered with an elastic and not slippery mat. The Contest Area may also be installed on a platform 0.6-1m high from the base, if necessary. The outer part of the Boundary Line shall be inclined at a gradient of less than 30 degrees, for the safety of the contestants. One of the following shapes can be used for Contest Area.

- 1.1 Square-shape

The Competition Area is comprised of a Contest Area and a Safety Area. The square-shape Contest Area shall be 8m x 8m. Surrounding the contest area, approximately equidistant on all sides, shall be the Safety Area. The size of Competition Area (which envelopes the Contest Area and the Safety Area) shall be no smaller than 10m x 10m and no larger than 12m x 12m. If the Competition Area is on a platform, the Safety Area can be increased as needed to ensure the safety of contestants. The Competition Area and the Safety Area shall be different colors, as specified in the relevant competition's Technical Manual.

- 1.2 Octagonal-shape

The Competition Area is comprised of a Contest Area and a Safety Area. The Competition Area shall be square shaped and the size shall be no smaller than 10mx10m and no larger than 12mx12m. At the center of the Competition Areas shall be the octagonal-shape Contest Area. The Contest Areas shall measure approximately 8m in diameter, and each side of the octagon shall have a length of approximately 3.3m. Between the outer line of the Competition area and the boundary line of the Contest area is the Safety Area. The Contest Area and the Safety Area shall be different colors, as specified in the relevant competition's Technical Manual.

- 2 Indication of positions

- 2.1 The outer line of the Contest Area shall be called the Boundary Line(s) and the outer line of the Competition Area shall be called the Outer Line(s).

- 2.2 The front outer line adjacent to the Recorder's Desk shall be called Outer Line #1, and Clockwise from Outer Line #1, the other lines shall be called Outer Lines #2, #3, and #4. The Boundary Line adjacent to the Outer Line #1 shall be called Boundary Line #1 and clockwise from Boundary Line #1, the other lines shall be called Boundary Lines #2, #3, and #4. In case of Octagonal Shape Contest Area, The Boundary Line adjacent to the Outer Line #1 shall be called Boundary Line #1 and clockwise from Boundary Line #1, the other lines shall be called Boundary Lines #2, #3, #4, #5, #6, #7, and #8.

- 2.3 Positions of Referee and Contestant at the beginning and end of the Match: The position of the Contestants shall be at the two opposing points, 1m from the center point of the Contest Area parallel to Outer Line #1. The Referee shall be positioned at a point 1.5m from the center of the Contest Area toward the Outer Line #3.

- 2.4 Positions of Judges: The position of the 1st Judge shall be located at a point 0.5m from the corner of the Outer Line #1 and #2. The position of the 2nd Judge shall be located at a point 0.5m outward from the center of the Outer Line #3. The position of the 3rd Judge shall be located at a point 0.5m from the corner of the Outer Line #1 and #4. In case of two Judges setting the position of the 1st Judge shall be located at a point 0.5m from the center of the Outer Line #3 and the 2nd Judge shall be located at a point 0.5m from the center of the Outer Line #1. The positions of Judges may be altered to facilitate media, broadcasting and/or sports presentation.

- 2.5 Position of Recorder & IVR: Position of Recorder & IVR shall be located at a point 2m from the Outer Line #1. Position of Recorder may be altered to accommodate the environment of the venue and requirements from media broadcasting and/or sports presentation.
- 2.6 Positions of Coaches: The position of the Coaches shall be marked at a point 1m or more from the center point of the Outer Line of each contestant's side. Position of the coaches may be altered to accommodate the environment of the venue and requirements from media broadcasting and/or sports presentation.
- 2.7 Position of Inspection desk: The position of the Inspection Desk shall be near the entrance of the Competition Area for the inspection of the contestants' protective equipment.

(Explanation #1)

Elastic mat: The degree of elasticity and slipperiness of the mat must be approved by the WTF before the competition.

(Explanation #2)

Color: The color scheme of the mat's surface must avoid giving a harsh reflection, or tiring the contestant's or spectator's eyesight. The color scheme must also be appropriately matched to the contestant's equipment, uniform and the surface of the Contest Area.

(Explanation #3)

Inspection Desk: At the Inspection desk, the inspector checks if all the materials worn by the contestant are approved by the WTF and fit the contestant properly. In case they are found to be inappropriate, the contestant is requested to change the protective equipment.

<Square-shape

Diagram 1. A court (코트 구성도)

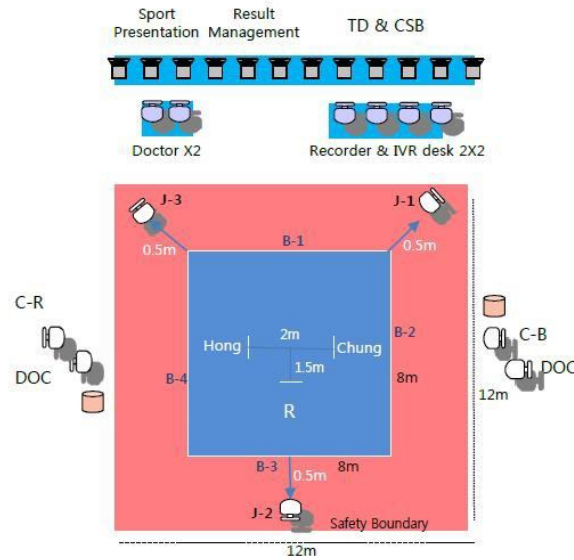

B 1~4	Boundary Lines #1 to # 4
J 1~3	Corner Judges # 1 to # 3
R	Center Referee
C-R	Coach (Red/Hong)
C- B	Coach(Blue/Chung)
DOC	Team Doctor
Doctor	Commission Doctor
IVR	Instant Video Replay Review Jury
TD & CSB	Technical Delegate & Competition Supervisory Board

Diagram 2. Competition Platform (경기대 그림)

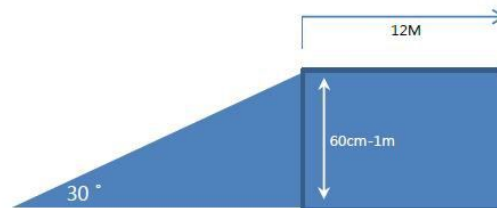

<Octagonal-shape

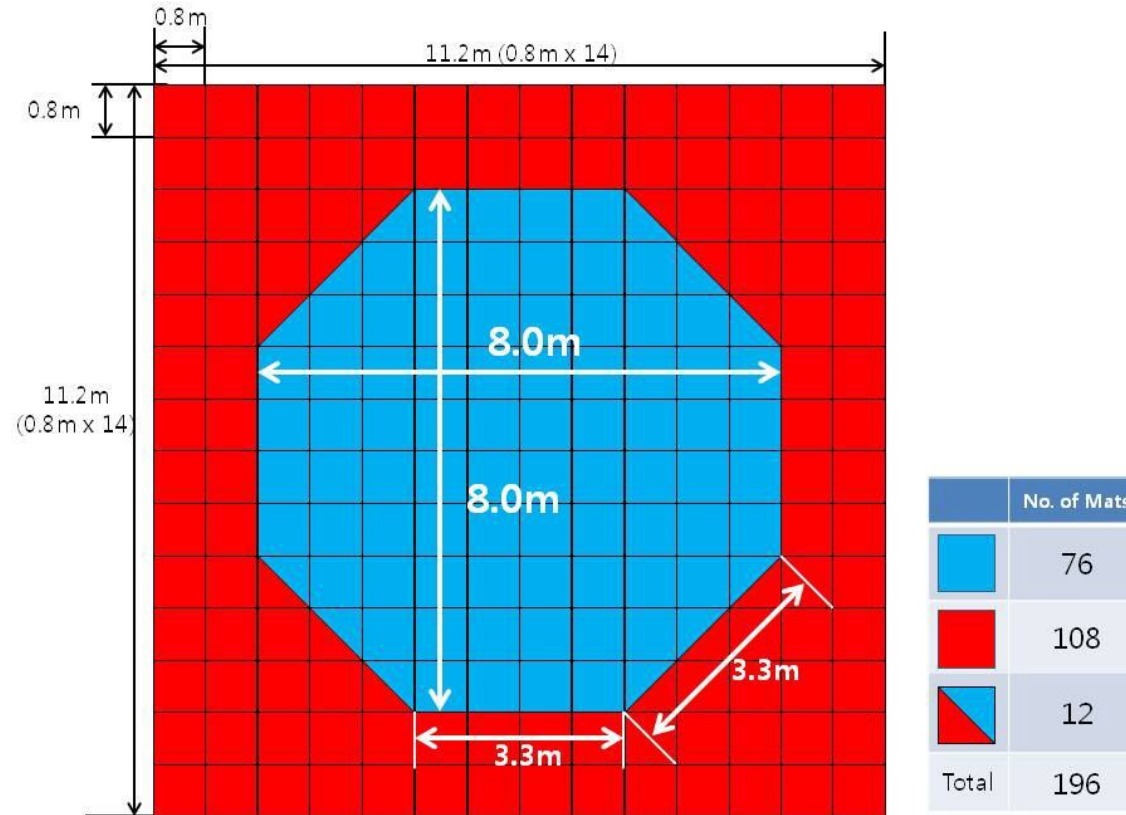

Article 4 **Contestant**

1 Qualification of Contestant

- 1.1 Holder of the nationality of the participating team
- 1.2 One recommended by the WTF National Taekwondo Association
- 1.3 Holder of Taekwondo Dan/Poom certificate issued by the Kukkiwon or WTF
- 1.4 Holder of the WTF Global Athlete License (GAL)
- 1.5 Contestants at the age of at least 17 years old in the year the pertinent tournament is held (15-17 years old for Junior Taekwondo Championships and 12-14 years old for Cadet Championships). Ages for Youth Olympic Games might be different depending on the decision of the IOC.

(Interpretation)

The age limit is based on the year, not on the date. For instance, if the Junior Taekwondo Championships are held on June 11, 2013, those contestants born on between January 1, 1996 and December 31, 1998 are eligible to participate.

Contestant uniform and competition equipment

- 1.6 At the competitions enlisted in the WTF Event Calendar, contestant uniform and all competition equipment such as but not limited to mats, PSS, IVR and protective equipment must be those ones approved by the WTF.
- 1.7 A contestant shall wear a WTF-approved uniform, trunk protector, groin guard, forearm guards, shin guards, hand protector, sensing socks (in the case of using PSS) and be equipped with a mouth piece before entering the Field of Play. Head protector must be firmly tucked under left arms when entering into competition area. Head protector shall be put on the head following instructions of the referee before the start of the contest.
- 1.8 The groin, forearm and shin guards shall be worn beneath the Taekwondo uniform. The contestant shall bring this WTF-approved protective equipment, as well as gloves and the mouthpiece, for his/her personal use. Wearing any item on the head other than the head protector shall not be permitted. Any religious item shall be worn beneath the head protector and inside the Dobok and shall not cause harm or obstruct the opposing contestant.
- 1.9 Specifications on taekwondo competition uniforms (Dobok), protective equipment, and all other equipment shall be set forth separately.
- 1.10 Responsibilities of the organizing committee for competition equipment
 - 1.10.1 The Organizing Committee of WTF-promoted Championships shall be responsible for preparing the following WTF-recognized equipment for the use at the Championships at its own expenses for all related materials, equipment and the related technicians for installation and operation.

PSS and PSS-related items and equipment – the choice of the PSS company shall be decided by the WTF

Mats

Headgears

Other protective equipment as reserve (Sensing socks, hand protectors, shin guards, forearm guards, groin guards and uniforms)

Instant Video Replay (IVR) system and its related equipment, including but not limited to cameras (minimum 3 cameras per court and minimum 4 cameras, including one overhead camera for the semifinals and final); When broadcasting is available, the broadcast feed must be made available at the Video Replay desk for review purpose

Jumbo screen (for display of competition progress) inside the FOP
Spectator scoreboards (for display of instant video replay screen;
minimum 12)
Scoreboards at the court (for display of scoring; minimum 4 per
court)
Other competition equipment not prescribed in this article, if any,
shall be described in Technical Manual of the WTF.

1.10.2 The Organizing Committee of WTF-promoted Championships shall be responsible for preparing the following equipment and materials, etc at the training venue at its own expenses.

PSS and PSS-related items and equipment
Mats
Items for first-aid
Ice in the baskets

1.10.3 It is the responsibility of the Organizing Committee to obtain approval of the WTF on the number of the equipment to be prepared.

2 Anti-Doping Test

- 2.1 At the Taekwondo events promoted or sanctioned by the WTF, any use or administration of drugs or chemical substances described in the WTF Anti-Doping Rules is prohibited. The WADA Anti-doping Code shall be applied to the Taekwondo competitions of the Olympic Games and other multi-sports Games.
- 2.2 The WTF may carry out any doping tests deemed necessary to ascertain if a contestant has committed a breach of this rule, and any winner who refuses to undergo this testing or who proves to have committed such a breach shall be removed from the final standings, and the record shall be transferred to the contestant next in line in the competition standings.
- 2.3 The Organizing Committee shall be responsible for making all necessary preparations for conducting doping tests.
- 2.4 The details of the WTF Anti-Doping Rules shall be enacted as part of the by-laws.

(Explanation #1)

Holder of the nationality of the participating team:

When a contestant is a representative of a national team, his/her nationality is decided by citizenship of the country he/she is representing before submission of the application to participate. Verification of citizenship is done by inspection of the passport.

A competitor who is a national of two or more countries at the same time may represent either one of them, as he may elect. However, after having represented one country in the Olympic Games, in Qualification Tournaments for Olympic Games, in continental or regional games or in world or regional championships Promoted or recognized by the WTF, he may not represent another country unless at least three (3) years have passed since the competitor last represented his former country. This period may be reduced or even cancelled, with the agreement of the NOCs and the WTF. The WTF may take disciplinary actions at any time against the athlete and his member national association that violates this article including but not limited to deprivation of the achievements. In case of an athlete aged 16 or less, this article shall not be applied unless there is an appeal from any of the two countries. In case of dispute, the WTF shall make evaluation and make a final decision. After the decision, no further appeal shall be acceptable.

(Explanation #2)

One recommended by the WTF National Taekwondo Association: Each National Federation is responsible for control of non-pregnancy and gender and shall ensure that all team members have been given medical exams that show them to be of adequate health and fitness to participate. Also each National Federation assumes full responsibilities for accident and health insurance as well as the civil liabilities for their contestants and officials during the WTF-promoted championships.

(Explanation #3)

Mouthpiece:

The color of the mouthpiece is limited to white or transparent. However, obligation to use mouthpiece may be exempted upon submission of the medical Doctor's diagnosis stating that use of mouthpiece may cause harm to the contestant.

(Explanation #4)

Headgear: The color of headgear other than blue or red shall not be permitted to compete.

(Explanation #5)

Instant Video Replay System: It is the responsibility of the Organizing Committee to ensure broadcasting feed is provided for Instant Video Replay review for the matches requested by the WTF.

(Explanation #6)

Taping: Taping of feet and hands will be strictly checked during the athlete inspection process. The inspector may request the Commission Doctor's approval for excessive taping.

Article 5 **Weigh Division**

- 1 Weight divisions are divided into male and female divisions, and classified into as follows.

Men's division		Women's division	
Under 54kg	Not exceeding 54kg	Under 46kg	Not exceeding 46 kg
Under 58kg	Over 54 kg & Not exceeding 58 kg	Under 49kg	Over 46 kg & Not exceeding 49 kg
Under 63kg	Over 58 kg & Not exceeding 63 kg	Under 53kg	Over 49 kg & Not exceeding 53 kg
Under 68kg	Over 63 kg & Not exceeding 68 kg	Under 57kg	Over 53 kg & Not exceeding 57 kg
Under 74kg	Over 68 kg & Not exceeding 74 kg	Under 62kg	Over 57 kg & Not exceeding 62 kg
Under 80kg	Over 74 kg & Not exceeding 80 kg	Under 67kg	Over 62 kg & Not exceeding 67 kg
Under 87kg	Over 80 kg & Not exceeding 87 kg	Under 73kg	Over 67 kg & Not exceeding 73 kg
Over 87kg	Over 87 kg	Over 73kg	Over 73 kg

2 Weight divisions of the Olympic Games are classified as follows.

Men's division		Women's division	
Under 58kg	Not exceeding 58kg	Under 49kg	Not exceeding 49kg
Under 68kg	Over 58kg & not exceeding 68kg	Under 57kg	Over 49kg & not exceeding 57kg
Under 80kg	Over 68kg & not exceeding 80kg	Under 67kg	Over 57kg & not exceeding 67kg
Over 80kg	Over 80kg	Over 67kg	Over 67kg

3 Weight divisions of WTF World Junior Taekwondo Championships are classified as follows.

Men's division		Women's division	
Under 45kg	Not exceeding 45kg	Under 42kg	Not exceeding 42 kg
Under 48kg	Over 45 kg & Not exceeding 48 kg	Under 44kg	Over 42 kg & Not exceeding 44 kg
Under 51kg	Over 48 kg & Not exceeding 51 kg	Under 46kg	Over 44 kg & Not exceeding 46 kg
Under 55kg	Over 51 kg & Not exceeding 55 kg	Under 49kg	Over 46 kg & Not exceeding 49 kg
Under 59kg	Over 55 kg & Not exceeding 59 kg	Under 52kg	Over 49 kg & Not exceeding 52 kg
Under 63kg	Over 59 kg & Not exceeding 63 kg	Under 55kg	Over 52 kg & Not exceeding 55 kg
Under 68kg	Over 63 kg & Not exceeding 68 kg	Under 59kg	Over 55 kg & Not exceeding 59 kg
Under 73kg	Over 68 kg & Not exceeding 73 kg	Under 63kg	Over 59 kg & Not exceeding 63 kg
Under 78kg	Over 73 kg & Not exceeding 78 kg	Under 68kg	Over 63 kg & Not exceeding 68 kg
Over 78kg	Over 78 kg	Over 68kg	Over 68 kg

4 Weight divisions of Youth Olympic Games are classified as follows.

Men's division		Women's division	
Under 48kg	Not exceeding 48kg	Under 44kg	Not exceeding 44kg
Under 55kg	Over 48kg & not exceeding 55kg	Under 49kg	Over 44kg & not exceeding 49kg
Under 63kg	Over 55kg & not exceeding 63kg	Under 55kg	Over 49kg & not exceeding 55kg
Under 73kg	Over 63kg & not exceeding 73kg	Under 63kg	Over 55kg & not exceeding 63kg
Over 73kg	Over 73kg	Over 63kg	Over 63kg

- 5 Weight divisions of WTF World Cadet Taekwondo Championships are classified as follows.

Men's division		Women's division	
Under 33kg	Not exceeding 33kg	Under 29kg	Not exceeding 29kg
Under 37kg	Over 33kg & not exceeding 37kg	Under 33kg	Over 29kg & not exceeding 33kg
Under 41kg	Over 37kg & not exceeding 41kg	Under 37kg	Over 33kg & not exceeding 37kg
Under 45kg	Over 41kg & not exceeding 45kg	Under 41kg	Over 37kg & not exceeding 41kg
Under 49kg	Over 45kg & not exceeding 49kg	Under 44kg	Over 41kg & not exceeding 44kg
Under 53kg	Over 49kg & not exceeding 53kg	Under 47kg	Over 44kg & not exceeding 47kg
Under 57kg	Over 53kg & not exceeding 57kg	Under 51kg	Over 47kg & not exceeding 51kg
Under 61kg	Over 57kg & not exceeding 61kg	Under 55kg	Over 51kg & not exceeding 55kg
Under 65kg	Over 61kg & not exceeding 65kg	Under 59kg	Over 55kg & not exceeding 59kg
Over 65kg	Over 65kg	Over 59kg	Over 59kg

(Explanation #1)

Not exceeding:

The weight limit is defined by the criterion of one decimal place away from the stated limit. For example, not exceeding 50kg is established as until 50.0kg with 50.1kg being over the limit and resulting in disqualification.

(Explanation #2)

Over:

Over 50.00 kg marks occur at the 50.1kg reading and 50.0kg and below is regarded as insufficient, resulting in disqualification.

Article 6 Classification and methods of competition

- 1 Competitions are classified as follows.
 - 1.1 Individual competition shall normally be between contestants in the same weight class. When necessary, adjoining weight class may be combined to create a single classification. No contestant is allowed to participate in more than one (1) weight category in one event.
 - 1.2 Team Competition: Method and weight divisions of team competition shall be stipulated in the Standing Procedures for WTF World Cup Taekwondo Team Championships.

- 2 Systems of competition are divided as follows.
 - 2.1 Single elimination tournament system
 - 2.2 Round robin system

- 3 Taekwondo competition of the Olympic Games shall use an individual competition system between contestants with the combination of single elimination tournament and repechage.
 - 4 All international-level competitions recognized by the WTF shall be formed with participation of at least 4 countries with no less than 4 contestants participated in each weight class, and any weight class with less than 4 participated contestants cannot be recognized in the official results.
 - 5 WTF World Taekwondo Grand Prix Series will be organized based on the most recent Standing Procedure of WTF World Taekwondo Grand Prix Series.
-

(Interpretation)

1. In the tournament system, competition is founded on an individual basis. However, the team standing can also be determined by the sum of the individual standings according to the overall scoring method.

*Point system

Team ranking shall be decided by the total points based on the following guidelines.

- Basic one (1) point per each contestant who entered the competition area after passing the official weigh-in - One (1) point per each win (win by a bye included)
- Additional seven (7) points per gold medal
- Additional three (3) points per silver medal
- Additional one (1) point per bronze medal

In case more than two (2) teams are tied in score, the rank shall be decided by 1) number of gold, silver and bronze medals won by the team in order, 2) number of participating contestants and 3) higher points in heavier weight categories.

2. In the team competition system, the outcome of each team competition is determined by the individual team results.

(Explanation #1)

Consolidated weight divisions:

The method of consolidation shall follow the Olympic weight divisions.

(Interpretation)

WTF World Cup Team Championships will be organized based on the most recent Standing Procedure of World Cup Team Championships.

Article 7 Duration of contest

- 1 The duration of the contest shall be three rounds of two minutes each, with a one-minute rest period between rounds. In case of a tie score after the completion of the 3rd round, a 4th round of two minutes will be conducted as the Golden Point round, after a one-minute rest period following the 3rd round.
- 2 The duration of each round may be adjusted to 1 minute x 3 rounds, 1 minute 30 seconds x 3 rounds or 2 minutes x 2 rounds upon the decision of the Technical Delegate for the pertinent Championships.

Article 8 Drawing of lots

- 1 The date of the drawing of lots shall be set forth in the outline of the championships. At the end of the designated registration date the OC shall announce the list of registered contestants in each weight category on the official website of the OC/WTF as the case may be. Participating teams are responsible for confirming their entries before the drawing of lots.
- 2 The drawing of lots may be conducted by random computerized drawing or by random manual drawing of lots. The method and order of drawing shall be determined by the Technical Delegate.
- 3 A certain number of contestants shall be seeded based on the WTF Ranking. The number of contestants seeded shall be set forth in the Standing Procedures of the championships or in the Outline of the championships. In CU Championships and WTF G2 events a minimum of 8 contests shall be seeded

Article 9 Weigh-in

- 1 Weigh-in of the contestants on the day of competition shall be completed on the previous day of the pertinent competition.
- 2 During weigh-in, the male contestant shall wear underpants and the female contestant shall wear underpants and a brassiere. However, weigh-in may be conducted in the nude if the contestant wishes to do so.
- 3 Weigh-in shall be made once, however, one more weigh-in is granted within the time limit to any contestant who did not qualify the first time.
- 4 So as not to be disqualified during official weigh-in, scales identical to the official one shall be provided at the contestants' place of accommodation or at the arena for pre-weigh-in.

(Explanation#1)

-The contestants on the day of competition:

This is defined as those contestants listed to compete on the scheduled day by the Organizing Committee or the WTF.

-The previous day of the pertinent competition:

The time for weigh-in will be decided by the Organizing Committee and participants should be informed at the head of team meeting. The duration of the weigh-in shall be 2 hours at the maximum.

(Explanation #2)

A separate site for the weigh-in shall be installed for the male and female contestants. The gender of weigh-in officials should be the same as that of the contestants.

(Explanation #3)

Disqualification during official weigh-in:

When a contestant is disqualified at the official weigh-in, the contestant's participation point shall not be awarded.

(Explanation #4)

Scales, identical to the official one:

The practice scale must be of the same type and calibrations as that of the official scale and these facts must be verified prior to the competition by the Organizing Committee.

Article 10 Procedure of the contest

- 1 Call for contestants: The name of the contestants shall be announced at the Athlete Calling Desk three (3) times beginning thirty (30) minutes prior to the scheduled start of the contest. If a contestant fails to report to the Desk following the third call, the contestant shall be disqualified, and this disqualification shall be announced.
- 2 Inspection of body, uniform and apparatus: After being called, the contestants shall undergo inspection of body, uniform and apparatus at the designated inspection desk by the inspectors designated by the WTF, and the contestant shall not show any signs of aversion, and also shall not wear any materials which may cause harm to the other contestant.
- 3 Entering the Competition Area: After inspection, the contestant shall proceed to the Coach's area with one coach and one team doctor or a physiotherapist (if any).
- 4 Procedure before the Beginning and after the End of the Contest
 - 4.1 Before the start of the contest, the center referee will call "Chung, Hong." Both contestants will enter the Contest Area with their headgears firmly tucked under their left arms. When any of contestant is not present or present without being fully attired, including all protective equipment, uniform, etc, at the Coach's Zone by the time the referee calls "Chung, Hong", he/she shall be regarded as withdrawn from the contest and the referee shall declare the opponent as the winner.
 - 4.2 The contestants shall face each other and make a standing bow at the referee's command of "Cha-ryeot (attention)" and "Kyeong-rye (bow)". A standing bow shall be made from the natural standing posture of "Charyeot" by bending the waist at an angle of more than 30 degrees with the head inclined to an angle of more than 45 degree. After the bow, the contestants shall put on their headgear.
 - 4.3 The referee shall start the contest by commanding "Joon-bi (ready)" and "Shi-jak (start)".
 - 4.4 The contest in each round shall begin with the declaration of "Shi-jak (start)" by the referee.
 - 4.5 The contest in each round shall end with the declaration of "Keu-man (stop)" by the referee. Even if the referee did not declare "Keu-man", the contest shall be deemed to have ended when the match clock expired.
 - 4.6 The referee may pause a contest by declaring "Kal- yeo" (separate) and resume the contest by the command of "Kye- sok" (continue). When the referee declares "Kal- yeo" the recorder should immediately stop the match time; when the referee declares "Kye-sok" the recorder should immediately restart the match time.
 - 4.7 After the end of the last round, the referee shall declare the winner by raising his/her hand to the winner's side. The contestants shall exchange bows with each other following the referee's declaration of the winner.
 - 4.8 Retirement of the Contestants
- 5 Contest Procedure in Team Competition
 - 5.1 Both teams shall stand facing each other in line in the submitted team order towards the 1st Boundary Line from the Contestants' marks.
 - 5.2 Procedure before the beginning and after the end of the contest shall be conducted as in clause 4 of this article.
 - 5.3 Both teams shall leave the Contest Area and stand by at the designated area for each contestant's match.
 - 5.4 Both teams shall line up in the Contest Area immediately after the end of the final match facing each other.
 - 5.5 The referee shall declare the winning team by raising his/her own hand to the winning team's side.

(Explanation#1) Team doctor or a physiotherapist:

At the time of submission of entry for team officials, copies of relevant and appropriate licenses of team doctor or physiotherapist written in English shall be attached. After verification, special accreditation cards shall be issued to those team doctors or physiotherapists. Only those who have obtained proper accreditation shall be allowed to proceed to Competition area with coach.

(Guideline for officiating)

In the case of using PSS, the referee shall check if the PSS system and sensing socks worn by both athletes are properly working. This process, however, may be deleted to save time for speedy competition management.

Article 11 Permitted techniques and areas

- 1 Permitted techniques
 - 1.1 Fist technique: A straight punching technique using the knuckle part of a tightly clenched fist
 - 1.2 Foot technique: Delivering techniques using any part of the foot below the ankle bone

- 2 Permitted areas
 - 2.1 Trunk: Attack by fist and foot techniques on the areas covered by the trunk protector are permitted. However, such attacks shall not be made on the part of the spine.
 - 2.2 Head: The area above the collar bone. Only foot techniques are permitted.

Article 12 Valid points

- 1 Scoring Areas
 - 1.1 Trunk: The blue or red colored area of the trunk protector
 - 1.2 Head: The entire head above the bottom line of the head protector

- 2 Criteria for valid point(s):
 - 2.1 Point(s) shall be awarded when a permitted technique is delivered to the scoring areas of the trunk with a proper level of impact.
 - 2.2 Point(s) shall be awarded when a permitted technique is delivered to the scoring areas of the head.
 - 2.3 If PSS is used, determination of the *validity* of the technique, level of impact, and/or valid contact to the scoring area shall be made by the electronic scoring system. These PSS determinations shall not be subject to Instant Video Replay.
 - 2.4 The WTF Technical Committee shall determine the required level of impact and sensitivity of the PSS, using different scales in consideration of weight category, gender, and age groups. In certain circumstances as deemed necessary the Technical Delegate may recalibrate the valid level of impact.

- 3 The valid points are as follows.
 - 3.1 One (1) point for a valid attack on trunk protector
 - 3.2 Three (3) points for a valid turning kick to the trunk protector
 - 3.3 Three (3) points for a valid kick to the head
 - 3.4 Four (4) points for a valid turning kick to the head
 - 3.5 One(1) point awarded for every two Kyung-gos or every one Gam-jeom given to the opponent contestant

- 4 Match score shall be the sum of points of the three rounds.
- 5 Invalidation of point(s): When a contestant records points while using prohibited act(s):
 - 5.1 If the prohibited act was instrumental to the scoring of the point(s), the referee shall declare the penalty for the prohibited act and invalidate of the point(s).
 - 5.2 However, if the prohibited act was not instrumental to earn the point, the referee may penalize the prohibited act but not invalidate the point(s).

Article 13 Scoring and publication

- 1 Scoring of valid point(s) shall be determined primarily using the electronic scoring system installed in Protector and Scoring Systems (PSS). Points awarded for punching techniques and additional points awarded for turning kicks shall be scored by judges using manual scoring devices. If PSS (Protector & Scoring System) is not used, all scoring shall be determined by judges using manual scoring devices.
- 2 If PSS for the head is not employed with PSS for the trunk, scoring for kicking techniques to the head shall be made by judges using the manual scoring devices.
- 3 The additional point given for a turning kick shall be invalidated if the turning kick was not scored as a valid point(s) by PSS.
- 4 Under a three (3) corner judge setting, two or more judges shall be needed to confirm valid scoring.
- 5 Under a two (2) corner judges setting, two judges shall be needed to confirm valid scoring.
- 6 If a referee perceives a contestant to be knocked down by a kick to the head, and so begins counting, but the attack was not scored by the PSS or Judges, the referee may request IVR to make the decision for awarding or not awarding points after the count.

Article 14 Prohibited acts and penalties

- 1 Penalties shall be declared by the referee.
- 2 Penalties consist of “Kyong-go (warning penalty)” and “Gam-jeom (deduction penalty)”.
- 3 Two “Kyong-go” shall be counted as an addition of one (1) point for the opposing contestant. However, the final odd numbered “Kyong-go” shall not be counted in the grand total.
- 4 A “Gam-jeom” shall be counted as one (1) additional point for the opposing contestant.

- 5 Prohibited acts.
 - 5.1 The following acts shall be classified as prohibited acts, and "Kyong-go" shall be declared.
 - 5.1.1 Crossing the Boundary Line
 - 5.1.2 Falling down
 - 5.1.3 Avoiding or delaying the match
 - 5.1.4 Grabbing, holding or pushing the opponent
 - 5.1.5 Lifting the knee to block or/and impede the opponent's kicking attack, or lifting a leg for more than 3 seconds, without execution of any attacking technique, to impede opponent's attacking movements
 - 5.1.6 Kicking below the waist
 - 5.1.7 Attacking the opponent after "Kal-yeo"
 - 5.1.8 Hitting the opponent's head with the hand
 - 5.1.9 Butting or attacking with the knee
 - 5.1.10 Attacking the fallen opponent
 - 5.1.11 Misconduct of contestant or coach
 - 5.2 In the case of serious misconduct of the prohibited acts by contestant or coach the referee shall declare "Gamjeom"
 - 5.3 When a coach or contestant commits excessive misconduct and does not follow the referee's command the referee may declare a sanction request by raising a yellow card. In this case the Competition Supervisory Board shall investigate the coach's behavior and determine whether a sanction is appropriate
- 6 If a contestant intentionally and repeatedly refuses to comply with the Competition Rules or the referee's orders, the referee may end the match and declare the opposing contestant the winner.
- 7 If the referee at the Inspection desk or officials in the Field of Play determines, in consultation with the PSS technician, if necessary, that a contestant or coach has attempted to manipulate the sensitivity of PSS sensor(s) and/or inappropriately alter the PSS so as to effect its performance, the contestant shall be disqualified.
- 8 When a contestant receives ten (10) "Kyong-go" or five (5) "Gam-jeom", or in the event of any combination of Kyonggo and Gam-jeom that add up to five penalty points, the referee shall declare the contestant loser by penalties.
- 9 In Article 14.8, "Kyong-go" and "Gam-jeom" shall be counted in the total score of the three rounds.

(Interpretation)

Objectives in establishing the prohibited acts and penalties are as follows,

- (1) To secure the contestant's safety
- (2) To ensure fair competition
- (3) To encourage appropriate techniques

(Explanation #1)

Kyong-go

i. Crossing the Boundary Line:

A "Kyong-go" shall be declared when both feet of a contestant cross the Boundary Line. No "Kyong-go" will be declared if a contestant crosses the boundary Line as a result of a prohibited act by the opposing contestant.

Falling down:

'Kyong-go' shall be declared for falling down. However if a contestant falls down due to the opponent's prohibited acts; 'Kyong-go' penalty shall not be given to the fallen contestant, while a penalty shall be given to the opponent. If both contestants fall as a result of incidental collision, no penalty shall be given.

ii. Avoiding or delaying the match:

a) This act involves stalling with no intention of attacking. A contestant who continuously displays a non-engaging style shall be given a penalty. If both contestants remain inactive after five (5) seconds, the center referee will signal the "Fight" command. A "Kyong-go" will be declared: On both contestants if there is no activity from them 10 seconds after the command was given; or on the contestant who moved backwards from the original position 10 seconds after the command was given.

b) Turning the back to avoid the opponent's attack and should be punished as it expresses the lack of a spirit of fair play and may cause serious injury. The same penalty should also be given for evading the opponent's attack by bending below waist level or crouching.

c) Retreating from the technical engagement only to avoid the opponent's attack and to run out the clock, "Kyong-go" shall be given to the passive contestant.

d) 'Pretending injury' means exaggerating injury or indicating pain in a body part not subjected to a blow for the purpose of demonstrating the opponent's actions as a violation, and also exaggerating pain for the purpose of elapsing the match time. In this case, the referee shall give a "Kyong-go" penalty.

e) "Kyong-go" shall also be given to the athlete who asks the referee to stop the contest in order to adjust the position/fit of protective equipment.

iii. Grabbing, holding or pushing the opponent:

This includes grabbing any part of the opponent's body, uniform or protective equipment with the hands. It also includes the act of grabbing the foot or leg or hooking either one on top of the forearm. For pushing, the following acts shall be penalized

a) pushing the opponent that causes the opponent to fall down,

b) pushing the opponent out of the boundary Line,

c) pushing the opponent in a way that hinders his/her kicking motion or any normal execution of technical movement.

iv. Lifting the knee to block or/and impede the opponent's kicking attack, or lifting a leg for more than 3 seconds, without execution of any attacking technique, to impede opponent's attacking movements.

-
- v. **Attacking below the waist:**
This action applies to an attack on any part below the waist. When an attack below the waist is caused by the recipient in the course of an exchange of techniques, no penalty will be given. This article also applies to strong kicking or stamping actions to any part of the thigh, knee or shin for the purpose of interfering with the opponent's technique.
- vi. **Attacking the opponent after "Kal-yeo":**
- a) Attacking after Kal-yeo requires that the attack results in actual contact to the opponent's body.
 - b) If the attacking motion started before the Kal-yeo, the attack shall not be penalized.
 - c) In Instant Video Replay review, the timing of Kal-yeo shall be defined as the moment that the referee's Kal-yeo hand signal was completed (with fully extended arm); and the start the attack shall be defined as the moment that the attacking foot is fully off the floor.
 - d) If an attack after Kal-yeo did not land on the opponent's body but appeared deliberate and malicious the referee may penalized the behavior with a "Kyong-go" (misconduct).
- vii. **Hitting the opponent's head with the hand:**
This article includes hitting the opponent's head with the hand (fist), wrist, arm, or elbow. However, unavoidable actions due to the opponent's carelessness such as excessively lowering the head or carelessly turning the body cannot be punished by this article.
- viii. **Butting or attacking with the knee:**
This article relates to an intentional butting or attacking with the knee when in close proximity to the opponent. However, contact with the knee that happens in the following situations cannot be punished by this article.
- When the opponent rushes in abruptly at the moment a kick is being executed
 - Inadvertently, or as the result of a discrepancy in distance in attacking.
- ix. **Attacking the fallen opponent:**
This action is extremely dangerous due to the high probability of injury to the opponent. The danger arises from the following:
- The fallen opponent is in an immediate defenseless state
 - The impact of any technique which strikes a fallen contestant will be greater due to the contestant's position. These types of aggressive actions toward a fallen opponent are not in accordance with the spirit of Taekwondo and as such are not appropriate to Taekwondo competition. In this regard, penalties should be given for intentionally attacking the fallen opponent regardless of the degree of impact
- x. **Misconduct of contestant or coach**
The following cases are Misconduct from a contestant or coach:
- a) Not complying with a referee's command or ruling
 - b) Inappropriate protesting or criticizing of officials' decisions
 - c) Leaving the designated coach's seat or standing up
 - d) Loud coaching during the rounds
 - e) Provoking or insulting officials, opposing contestant, coach, or spectators
 - f) Any other undesirable behavior or unsportsmanlike conduct from a contestant or coach

Contestant and coach's misconduct can be subject to either (5.1.11) "Kyong-go" or (5.2.) "Gam-jeom". When the severity of the conduct is light a "Kong-go" shall be given and when extreme a "Gam-jeom" shall be given. The determination of the seriousness of the misconduct is solely at the referee's discretion. If misconduct is repeated after "Kyong-go" the referee may give a "Gam-jeom" even if the behavior is the same.

When misconduct is committed by a contestant or a coach during a rest period, the referee can immediately declare the penalty and the penalty shall be recorded in the next round's results.

(Explanation #2)

Gam-jeom

i. Serious misconducts of contestants or coaches

The following cases are serious misconducts by contestants or coaches

- a) Not complying with the referee's command or decision
- b) Inappropriate protesting or criticizing of officials' decisions
- c) Inappropriate attempts to disturb or influence the outcome of the match
- d) Fleeing from the competition area to avoid normal technical exchange. If a contestant attempts to avoid a normal technical exchanges by behavior such as crossing the boundary line or intentionally falling down in repeated manner, the referee may give a Gam-jeom, after a Kyong-go
- e) Clearly intentional punch to the opponent's face
- f) Clearly intentional attack the opponent after "kal-yeo"
- g) Clearly intentional attack to a fallen opponent
- h) Clearly intentional attack below the waist
- i) Provoking or insulting the opposing contestant or coach
- j) Only accredited team doctor/physician are allowed to be seated in the doctor's position. Unaccredited doctor/physicians or other team officials found to be seated in the doctors position shall be ordered to leave the FOP, and the athlete shall be penalized with a "Gam-jeom"
- k) Any other severe misconduct or unsportsmanlike conduct from a contestant or coach

Misconduct by a contestant or coach can be subjected to either (5.1.9) "Kyong-go" or (5.2.5) "Gam-jeom". When the misconduct is less serious a "Kong-go" shall be given and when the case is serious or extreme a "Gam-jeom" shall be given. The determination of the seriousness of the misconduct is solely the referee's discretion. If misconduct was repeated after a "Kyong-go" the referee may give a "Gam-jeom" even for the same behavior.

When misconduct is committed by a contestant or a coach during the rest period, the referee can immediately declare the penalty and that penalty shall be recorded on the next round's results,

Article 15 Golden point and decision of superiority

- 1 In the event the winner cannot be decided after 3 rounds, a 4th round will be conducted.
- 2 In case of a contest advances to a 4th round, all scores awarded during the first three (3) rounds shall be void.
- 3 The first contestant to score a point or whose opponent receives two kyong-gos or one gam-jeom in the extra round shall be declared the winner.
- 4 In the event that neither contestant has scored a point after the completion of the 4th round, the winner shall be decided by superiority based the following criteria:
 - 4.1 The contestant who achieved a higher number of hits registered by the PSS during the 4th round.
 - 4.2 If number of hits registered by the PSS is tied, the contestant who received less numbers of a Kyong-go and Gam-jeom (=2 Kyong-gos) during all four rounds
 - 4.3 If the two above criteria are the same, the referee and judges shall determine superiority based on the content of the 4th round. If the superiority decision is tied among the referee and judges, the referee shall decide the winner.

(Explanation #1)

Decision of superiority by judges shall be based on technical dominance of an opponent through aggressive match management, the greater number of techniques executed, the use of the more advanced techniques both in difficulty and complexity, and display of the better competition manner.

(Explanation #2)

In the event that one athlete delivers successful head kick right before the opponent's body kick but the latest body kick was registered, the coach of the athlete who delivered head kick may request for video replay. If review jury determines that head kick was valid and performed earlier than body kick, the referee shall invalidate the point(s) scored by body kick, then declare 3 or 4 points for head kick, and declare the one who delivered head kick as winner.

(Guideline for officiating)

The procedure for superiority decision shall be as follows.

- 1) Prior to the contest, all refereeing officials take the superiority card with them.
- 2) When a match is to be decided by superiority, the referee shall declare "Woo-se-girok (Record Superiority)".
- 3) Upon the referee's declaration, the judges shall record the winner within 10 seconds with their heads down, sign on the card and then give it to the referee.
- 4) The referee shall collect all superiority cards, record the final result, and then declare the winner.
- 5) Upon declaration of winner, the referee shall hand over the cards to the recorder and the recorder shall submit the cards to the Technical Delegate of World Taekwondo Federation.

Article 16 Decisions

- 1 Win by Referee Stops Contest (RSC)
- 2 Win by final score (PTF)
- 3 Win by point gap (PTG)
- 4 Win by Golden Point (GDP)
- 5 Win by Superiority (SUP)
- 6 Win by withdrawal (WDR)
- 7 Win by disqualification (DSQ)
- 8 Win by referee's punitive declaration (PUN)

(Explanation #1)

Referee Stops Contest:

The referee declares RSC in the following situations:

- i. if a contestant has been knocked down by an opponent's legitimate technique and cannot resume the contest by the count of "Yeo-dul"; or if the referee determines the contestant is not able to resume the competition regardless of the progress of counting;
- ii. If a contestant cannot continue the match after one minute of medical treatment;
- iii. if a contestant disregards the referee's command to continue the match three times;
- iv. if the referee recognizes the need to stop the match to protect a contestant's safety;
- v. when the Commission Doctor determines that the match should be stopped due to a contestant's injury;

(Explanation #2)

Win by point gap: In case of 12 points difference between two athletes at the time of the completion of 2nd round and/or at any time during the 3rd round, the referee shall stop the contest and shall declare the winner by point gap.

(Explanation #3)

Win by withdrawal: The winner is determined by withdrawal of the opponent.

- When a contestant withdraws from the match due to injury or other reasons
- When a contestant does not resume the match after the rest period or fails to respond to the call to begin the match
- When the coach throws a towel into the court to signify forfeiture of the match

(Explanation #4)

Win by disqualification: This is the result determined by the contestant's failure in weigh-in or when a contestant loses contestant status before the competition begins.

The follow-up actions should be different in accordance with the reason of disqualification.

- i. (In the event that athletes have not passed or did not show at weigh-in after draw: The result should be reflected on the draw sheet and the information should be provided to technical officials and all relevant persons. Referees will not be assigned for this match. The opponent of athletes that did not pass or show at weigh-in will not need to appear at the court to compete.
- ii. In the event that an athlete passed weigh-in but did not appear at the Coach's zone: The assigned referee and opponent shall be waiting in their position until the referee declares the opponent a winner of the match. Detailed procedure is stipulated in 4.1 of Article 10.

(Explanation #5)

Win by the referee's punitive declarations:

The referee declares PUN in the following situations:

- i. If a contestant accumulated ten (10) "Kyong-go" or five (5) "Gam-jeom" or their combination of five (5) penalty points;
- ii. if it is determined that a contestant manipulates the sensor(s) or scoring system of the PSS;
- iii. if a contestant or coach refuses to follow the referee's commands or to comply the Competition Rules, or commits other serious infringing behavior including improper protest.

Article 17 Knock Down

A Knock Down shall be declared, when a legitimate attack is delivered and;

- 1 When any part of the body other than the sole of the foot touches the floor due to the force of the opponent's scoring technique
- 2 When a contestant is staggered and shows no intention or ability to continue as a result of the opponent's scoring techniques.
- 3 When the referee judges that the contest cannot continue as the result of being struck by a legitimate scoring technique

(Explanation #1) A knock down:

This is the situation in which a contestant is knocked to the floor or is staggered or unable to respond adequately to the requirements of the match due to a blow. Even in the absence of these indications, the referee may interpret as a knock down, the situation where, as the result of contact, it would be dangerous to continue or when there is any question about the safety of a contestant.

Article 18 Procedure in the event of a Knock Down

- 1 When a contestant is knocked down as the result of the opponent's legitimate attack, the referee shall take the following measures.
 - 1.1 The referee shall keep the attacker away from downed contestant by declaration of "Kal-yeo (break)".
 - 1.2 The referee shall first check the status of the downed contestant and count aloud from "Ha-nah (one)" up to "Yeol (ten)" at one second intervals towards the downed contestant, making hand signals indicating the passage of time.
 - 1.3 In case the downed contestant stands up during the referee's count and desires to continue the fight, the referee shall continue the count up to "Yeo-dul (eight)" for recovery of the contestant. The referee shall then determine if the contestant is recovered and, if so, continue the contest by declaration of "Kye-sok (continue)".
 - 1.4 When a contestant who has been knocked down cannot demonstrate the will to resume the contest by the count of "Yeo-dul (eight)", the referee shall announce the other contestant winner by RSC(Referee Stops Contest).
 - 1.5 The count shall be continued even after the end of the round or the expiration of the match time.
 - 1.6 In case both contestants are knocked down, the referee shall continue counting as long as one of the contestants has not sufficiently recovered.
 - 1.7 In case both contestants are knocked down and both contestants fail to recover by the count of "Yeol", the winner shall be decided by the match score before the occurrence of Knock Down.
 - 1.8 When it is judged by the referee that a contestant is unable to continue, the referee may decide the winner either without counting or during the counting.
- 2 Procedures to be followed after the contest: Any contestant who could not continue the match as a result of a serious injury regardless of any parts of the body cannot enter competition within thirty (30) days without approval of the WTF Medical Chairman after submission of a statement from the physician designated by the pertinent national federation.

(Explanation #1)

Keep the attacker away:

In this situation the standing opponent shall return to the respective contestant's mark, however, if the downed contestant is on or near the opponent's contestant's mark, the opponent shall wait at the boundary line in front of his/her coach's chair.

(Guideline for officiating)

The referee must be constantly prepared for the sudden occurrence of a knock down or situation where the contestant is staggered, which is usually characterized by a powerful blow accompanied by impact.

(Explanation #2)

In case the downed contestant stands up during the referee's count and desires to continue the fight:

The primary purpose of counting is to protect the contestant. Even if the contestant desires to continue the match before the count of eight is reached, the referee must count until "Yeo-dul (eight)" before resuming the match.

Counting to "Yeo-dul" is compulsory and cannot be altered by the referee.

**Count from one to ten: Ha-nah, Duhi, Seht, Neht, Da-seot, Yeo-seot, Il-gop, Yeo-dul, A-hop, Yeol.*

(Explanation #3)

The referee shall then determine if the contestant has recovered and, if so, restart the contest by the declaration of "Kye-sok":

The referee must ascertain the ability of the contestant to continue while he/she counts until eight. Final confirmation of the contestant's condition after the count of eight is only procedural and the referee must not needlessly pass time before resuming the contest.

(Explanation #4)

When a contestant who has been knocked down cannot express the will to resume by the count of "Yeo-dul", the referee shall announce the other contestant winner by RSC. after counting to "Yeol":

The contestant expresses the will to continue the match by gesturing several times in a fighting position with the clenched fists. If the contestant cannot display this gesture by the count of "Yeo-dul", the referee must declare the other contestant winner after first counting "A-hop" and "Yeol". Expressing the will to continue after the count of "Yeo-dul" cannot be considered valid. Even if the contestant expresses the will to resume by the count of "Yeo-dul", the referee can continue counting and may declare the contest over if he/she determines the contestant is incapable of resuming the match.

(Explanation #5)

When a contestant is downed by a powerful scoring blow and whose condition appears serious, the referee can suspend the count and call for first aid or do so in conjunction with the count.

(Guideline for officiating)

- i. The referee must not spend additional time confirming the contestant's recovery after counting to "Yeodul" as a result of failing to observe that condition during the administration of the count.
- ii. When the contestant clearly recovers before the count of "Yeo-dul" and expresses the will to resume and the referee can clearly discern the contestant's condition yet resumption is hampered by the requirement of medical treatment, the referee must first resume the match with the declaration of "Kye-sok" and immediately after declare "Kal-yeo" and "Kye-shi" and then follow the procedures of Article 19.

Article 19 Procedures of suspending the match

- 1 When a contest is to be stopped due to the injury of one or both contestants, the referee shall take the measures prescribed below. However, in a situation which warrants suspending the contest for reasons other than an injury, the referee shall declare “Shi-gan (time)” and resume the contest by declaring “Kye-sok (continue)”.
 - 1.1 The referee shall suspend the contest by declaration of “Kal-yeo” and order the recorders to suspend the time by announcing “Kye-shi (suspend)”.
 - 1.2 The referee shall allow the contestant one minute to receive first aid by the commission doctor; the referee may allow team doctor to treat first aid if the commission doctor is not available or if it is deemed necessary.
 - 1.3 If an injured contestant cannot return to the match after one minute the referee shall declare the other contestant winner.
 - 1.4 In case resumption of the contest is impossible after one minute, the contestant causing the injury by a prohibited act to be penalized by “Gam-jeom” shall be declared the loser.
 - 1.5 In case both the contestants are knocked down and are unable to continue the contest after one minute, the winner shall be decided upon points scored before the injuries occurred.
 - 1.6 If the referee determines a contestant’s pain is caused only by a bruise the referee shall declare “Kal-yeo” and give a command to resume the match with the call, “stand-up”. If the contestant refuses to continue the match after the referee gives the command “stand up” three times, the referee shall declare the match ‘Referee Stops Contest’.
 - 1.7 If the referee determines a contestant has received an injury such as broken bone(s), dislocation, sprain ankle(s), and/or bleeding, the referee shall allow the contestant to receive a first aid treatment for one minute after “Kye-shi”. The referee may allow the contestant to receive first aid treatment even after giving the commanding “stand-up” if the contestant is determined to be injured in one of the categories above.
 - 1.8 Stopping the match due to injury: If the referee determines a contestant has received an injury such as broken bone(s), dislocation, sprain ankle(s), and/or bleeding, the referee shall consult with the chairperson of the Medical Committee or the commissioned doctor assigned by the chairperson. If a contestant is re-injured in the same manner, the chairperson of the Medical Committee or the commission doctor assigned by the chairman may advise the referee to stop the match and declare the injured the loser.

(Explanation #1)

When the referee determines that the competition cannot be continued due to injury or any other emergency situation, he/she may take the following measures:

- i. If the situation is critical such as a contestant losing consciousness or suffering from a severe injury and time is crucial, first aid must be immediately directed first and the match must be closed. In this case, the result of the match will be decided as follows.
 - The contestant causing the injury shall be declared the loser if the outcome was the result of a prohibited act to be penalized by “Gam-jeom”.
 - The incapacitated contestant shall be declared the loser if the outcome was the result of a legal action or accidental, unavoidable contact.
 - If the outcome was unrelated to the match contents, the winner shall be decided by the match score before suspension of the match. If the suspension occurs before the end of the first round, the match shall be invalidated.
- ii. If first aid treatment is need for an injury, the contestant can receive necessary treatment within one minute after the declaration of “Kye-shi”.

- a) Order to resume the match: It is the decision of the center referee, after consultation with the Commission Doctor, whether or not it is possible for the contestant to resume the match. The referee can anytime order the contestant to resume the match within one minute. The referee can declare any contestant who does not follow the order to resume the match the loser of the contest.
 - b) While the contestant is receiving medical treatment or is in the process of recovering, 40 seconds after the declaration of "Kye-shi", the referee begins to loudly announce the passage of time in five second intervals. When the contestant cannot return to the Contestant's Mark by the end of the one minute period, the match results must be declared.
 - c) After the declaration of "Kye-shi", the one minute time interval must be strictly observed regardless of the Commission Doctor's availability. However, when the doctor's treatment is required but the doctor is absent or additional treatment is necessary, the one minute time limit can be suspended by the judgment of the referee.
 - d) If resumption of the match is impossible after one minute, the decision of the match will be determined according to sub-article "i" of this article.
- iii. If both contestants become incapacitated and are unable to resume the match after one minute or urgent conditions arise, the match result is decided according to the following criteria:
 - If the outcome is the result of a prohibited act to be penalized by "Gam-jeom" by one contestant that person shall be the loser.
 - If the outcome was not related to any prohibited act to be penalized by "Gam-jeom", the result of the match shall be determined by the match score at the time of suspension of the match. However, if the suspension occurs before the end of the first round, the match shall be invalidated and the Organizing Committee will determine an appropriate time to re-contest the match. The contestant who cannot resume the match shall be deemed to have withdrawn from the match.
 - If the outcome is the result of prohibited acts to be penalized by "Gam-jeom" by both contestants, then both contestants shall lose.

(Explanation #2)

The situation which warrants suspending the match beyond the above-prescribed procedures shall be treated as follows.

- i. When uncontrollable circumstances require suspension of the match, the referee shall suspend the match and follow the directives of the Technical Delegate.
- ii. If the match is suspended after the completion of the second round, the outcome shall be determined according to the match score at the time of suspension.
- iii. If the match is suspended before the conclusion of the second round, a rematch shall, in principle, be conducted and shall be held in three rounds.

Article 20 Technical Officials

1 Technical Delegate (TD)

- 1.1 Qualification: Chairman of WTF Technical Committee shall serve as the TD at the WTF-promoted championships except WTF World Taekwondo Poomsae Championships and WTF World Para-Taekwondo Championships. In case of absence of Chairman of WTF Technical Committee, WTF President can appoint TD upon recommendation of WTF Secretary General..
- 1.2 Roles: TD is responsible to ensure that WTF Competition Rules are properly applied and preside over the Head of Team meeting and drawing of lots session. TD approves the result of draw, weigh-in and competitions before it being officialized. TD has the right to make final decisions on competition area and overall technical matters on competitions in consultation with Competition Supervisory Board. TD shall make final decisions on any matters pertaining to competitions not prescribed in Competition Rules. TD serves as the Chairman of Competition Supervisory Board.

- 2 Competition Supervisory Board (CSB) Member
 - 2.1 Qualification: CSB members shall be appointed by the WTF President upon recommendation of Secretary General from those who have sufficient experience and knowledge of taekwondo competitions.
 - 2.2 Composition: CSB shall consist of one Chairperson and no more than 6 members at WTF-promoted championships. Chairpersons of WTF Games Committee, WT Referee Committee, and WTF Medical Committee and WTF Athlete Committee shall be included in CSB as ex-officio members. The composition, however, may be adjusted by the President, if necessary.
 - 2.3 Roles: CSB shall assist TD in competitions and technical matters and ensure the competitions are held in accordance with the schedule. CSB shall evaluate the performances of Review Jury and refereeing officials. CSB shall also concurrently act as the Extraordinary Sanctions Committee during competition with regard to competition management matters.

- 3 Review Jury (RJ)
 - 3.1 Qualification: RJ shall be appointed by WTF President upon recommendation of WTF Referee Chairman from those who are experienced and highly qualified International Referees.
 - 3.2 Composition: One (1) RJ and one (1) assistant to RJ shall be allocated per court.
 - 3.3 Roles: RJ shall review an instant replay and inform the referee of the decision within one (1) minute.

- 4 Refereeing officials
 - 4.1 Qualification: Holders of International Referee Certificate registered by the WTF
 - 4.2 Duties
 - 4.2.1 Referee
 - 4.2.1.1 The referee shall have control over the match.
 - 4.2.1.2 The referee shall declare “Shi-jak”, “Keu-man”, “Kal-yeo”, “Kye-sok”, “Kye-shi”, “Shi-gan”, winner and loser, deduction of points, warnings and retiring. All the referees' declarations shall be made after the results are confirmed.
 - 4.2.1.3 The referee shall have the right to make decisions independently in accordance with the prescribed rules.
 - 4.2.1.4 In principle, the center referee shall not award points. However, if one of the corner judges raises his/her hand because a point was not scored, then the center referee will convene a meeting with the judges. If it was found that two corner judges request for change of the judgment, the referee must accept and correct the judgment (in case of 1 referee + 3 judges). In a two corner judge setting, the result of the scoring can be revised when two persons among two judges and the referee agree to do so.
 - 4.2.1.5 In case as defined by the Article 15, the decision of superiority shall be made by refereeing officials after the end of four (4) rounds when necessary.
 - 4.2.2 Judges
 - 4.2.2.1 The judges shall mark the valid points immediately.
 - 4.2.2.2 The judges shall state their opinions forthrightly when requested to do so by the referee.
 - 4.2.3 Technical Assistant
 - 4.2.3.1 TA shall keep monitoring scoreboard during the contest if the scoring, penalties and timing are correctly publicized, and immediately notify the referee of any problematic issue in this regard.
 - 4.2.3.2 TA shall notify the referee of starting or stopping the contest in close communication with system operator and recorder.
 - 4.2.3.3 TA manually records all scores, penalties and IVR result in TA paper.
 - 4.3 Composition of refereeing officials per court
 - 4.3.1 The officials' squad is composed of one (1) referee and three (3) judges.
 - 4.3.2 The officials' squad is composed of one (1) referee and two (2) judges
 - 4.3.3

4.4 Assignment of refereeing officials

4.4.1 The assignment of the referees and judges shall be made after the contest schedule is fixed.

4.4.2 Referees and judges with the same nationality as that of either contestant shall not be assigned to such a contest. However, an exception can be made for the judges when the number of refereeing officials is insufficient.

4.5 Responsibilities for decisions: Decisions made by the referees and judges shall be conclusive and they shall be responsible to the Competition Supervisory Board for the content of those decisions.

4.6 Uniforms

4.6.1 The referees and judges shall wear the uniform designated by the WTF.

4.6.2 The refereeing officials shall not carry or take any materials to the contest area which might interfere with the contest. Use of mobile phones by refereeing officials in the field of play may be restricted, if necessary.

5 Recorders: The recorder shall time the contest, periods of time-out, and suspensions, and also shall record and publicize the awarded points, and/or penalties.

(Interpretation)

The details of the refereeing official's qualifications, duties, organization, etc. shall follow the WTF Regulations on the Administration of International Referees.

(Interpretation)

TD may replace or penalize the refereeing officials in consultation with CSB in the event that refereeing officials have been wrongly assigned, or when it is judged that any of the assigned refereeing officials have unfairly conducted the contest or made unjustifiable mistakes repeatedly.

(Guideline for officiating)

In case that each judge awards different score respectively to the legal attack on the face, for instance, one judge gives one point, another gives two and the other gives no point, and that no point is recognized as a valid one, or in the case that the recorder makes mistakes in timing, scoring or penalties, any of the judges may indicate the mistake and ask for confirmation among the judges. Then, the referee may declare "Shi-gan (time)" to stop the contest and gather the judges to ask for a statements. After discussion, the referee must publicize the resolution. In the case that a coach requests for video review for the same case that one of the judges requests for a meeting between refereeing officials, the referee shall first gather judges before taking the request from coach. If it has been decided to correct the decision, the coach shall remain seated without using appeal quota. If the coach still stands and request for video review, the referee shall take the coach's request. This article also applied to the case that the referee makes an error in judgment of knock-down, and the judges may raise a different opinion to the referee while the referee counts "Seht (three)" or "Neht (four)".

Article 21 Instant video replay

- 1 In case there is an objection to a judgment of the refereeing officials during the contest, the coach of a team can make a request to the center referee for an immediate review of the video replay. The coach can only request video review for penalties against the opponent for instances of falling down or crossing the boundary line
- 2 When coach appeals, the center referee will approach the coach and ask the reason for the appeal. Scope of the appeal for the video replay is limited to the errors of the center referee in application of Competition Rules, points scored by the judges and penalties. Any appeal shall not be admissible on any points scored by foot or fist attacks on the trunk regardless of the use of PSS, except the technical points given to attacks to the trunk. The scope of instant video replay request is limited to the only one action which has occurred within five (5) seconds from the moment of the coach's request. Once the coach rises the blue or red card to request for instant video replay, it will be considered that the coach has used his/her allocated appeal under any circumstance unless the judge's meeting satisfies the coach.

- 3 Referee shall request the Review Jury to review the instant video replay. Review Jury, who is not of the same nationality as the contestants, shall review the video replay.
- 4 After review of the instant video replay, the Review Jury shall inform the center referee of the final decision within one (1) minute after receiving the request.
- 5 Each coach shall be allocated with one (1) appeal to request an instant video replay request per contest. If the appeal is successful and the contested point is corrected, the coach shall retain the appeal right for the pertinent contest.
- 6 In the course of one (1) Championship, there is no limit of total number of appeals a coach has the right to make per contestant. However, if any coach has had certain number of appeals rejected for one contestant, he/she will lose the right to any further appeals. Based on the size and level of the Championships, the Technical Delegate may decide the number of appeal quota between one (1) and three (3) per Championships.
- 7 The decision of the Review Jury is final; no further appeals during the contest or protest after the contest will be accepted.
- 8 In the case that there is a clear erroneous decision from the refereeing officials on identification of the contestant or errors in the scoring system, any of the judges shall request for review and correct the decision at any time during the contest. Once the refereeing officials leave the contest area, it will not be possible for anyone to request for review or to change the decision.
- 9 In the case of a successful appeal, the Competition Supervisory Board may investigate the contest at the end of the competition day and take disciplinary action against the concerned refereeing officials, if necessary.
- 10 In the last 10 seconds of the 3rd round and in any time during Golden Point round, any of the judges can ask for review and correction of scoring when a coach does not have appeal quota.
- 11 In the tournament where instant video replay system is not available, the following protest procedure will be applied.
 - 11.1 In case there is an objection to a referee judgment, an official delegate of the team must submit an application for re-evaluation of decision (protest application) together with the non-refundable protest fee of US\$200 to the Board of Arbitration (Competition Supervisory Board) within 10 minutes after pertinent contest.
 - 11.2 Deliberation of re-evaluation shall be carried out excluding those members with the same nationality as that of contestant concerned, and resolution on deliberation shall be made by majority.
 - 11.3 The members of the Board of Arbitration (Competition Supervisory Board) may summon the refereeing officials for confirmation of events.
 - 11.4 The resolution made by the Board of Arbitration (Competition Supervisory Board) will be final and no further means of appeal will be applied.
 - 11.5 Deliberation procedures are as follows:
 - 11.5.1 A coach or head of team from the protesting nation shall be permitted to make a brief verbal presentation to the Board of Arbitration in support of their position. The coach or head of team from the respondent nation shall be allowed to present a brief rebuttal.
 - 11.5.2 After reviewing the protest application, the contest of the protest must be arranged according to the criterion of "Acceptable" or "Unacceptable".
 - 11.5.3 If necessary, the Board can hear opinions from the referee or judges.
 - 11.5.4 If necessary, the Board can review the material evidence of the decision, such as the written or visual recorded data.

- 11.5.5 After deliberation, the Board shall hold the secret ballot to determine a majority decision.
- 11.5.6 The Chairperson will make a report documenting the outcome of the deliberation and shall make this outcome publicly known.
- 11.5.7 Subsequent process following the decision:
 - 11.5.7.1 Errors in determining the match results, mistakes in calculating the match score or misidentifying a contestant shall result in the decision being reversed.
 - 11.5.7.2 Error in application of the rules: When it is determined by the Board that the referee made a clear error in applying the Competition Rules, the outcome of the error shall be corrected and the referee shall be punished.
 - 11.5.7.3 Errors in factual judgment: When the Board decides that there was a clear error in judging the facts such as impact of striking, severity of action or conduct, intention, timing of an act in relation to a declaration or area, the decision shall not be changed and the officials seen to have made the error shall be reprimanded.

Article 22 Para-Taekwondo

This article outlines the modifications to the Competition Rules used for Para-Taekwondo. For matters not covered by Article 22 the WTF Competition Rules will apply.

1. Qualification of Contestant
 - 1.1 Holder of Taekwondo 3-1 Gup recognized by WTF MNA or Dan/Poom certificate issued by the Kukkiwon or WTF
 - 1.2 Contestants at the age of at least 16 years old in the year the pertinent tournament is held
 - 1.3 Contestant must have gone through classification procedures as outlined in the WTF Para-Taekwondo Classification Rules and Regulations and has been assigned Sport Class and Sport Class Status

2. Contestant Uniform and Equipment

Contestant shall wear WTF approved uniform and equipment as far as allowed by limb deficiency. In the case of amputation the uniform sleeve/s has to be cut no more than five (5) centimeters below the limb.

3. Para-Taekwondo weight divisions are divided into male and female divisions, as follows;

Men's division		Women's division	
Under 61kg	Not exceeding 61kg	Under 49kg	Not exceeding 49kg
Under 75kg	Over 61kg & not exceeding 75kg	Under 58kg	Over 49kg & not exceeding 58kg
Over 75kg	Over 75kg	Over 58kg	Over 58kg

4. Duration of contest

The duration of the contest shall be three rounds of two minutes each, with a one-minute rest period between rounds. In case of a tie score after the completion of the 3rd round, a 4th round of two minutes will be conducted as the Golden Point Round, after a one-minute rest period following the 3rd round.

The duration of each round may be adjusted to 1 minute x 3 rounds, 1 minute 30 seconds x 3 rounds or 2 minutes x 2 rounds upon the decision of the Technical Delegate for the pertinent Championships. The Technical Delegate needs to take classification into consideration when deciding duration of contest. Different duration of contest can be used for different classes.

5. Permitted techniques and areas
 - 5.1 Permitted techniques

Fist technique: A straight punching technique using the knuckle part of a tightly clenched fist. In the case that the athlete is unable to make a fist with either one or both hands the athlete will not be able to score points by punching.

Foot technique: Delivering techniques using any part of the foot below the ankle bone
 - 5.2 Permitted areas

Trunk: Attack by fist and foot techniques on the areas covered by the trunk protector are permitted. However, such attacks shall not be made on the part of the spine.

Head: No attacks to the head are permitted
 - 5.3 Scoring area

Body: The blue or red colored area of the body protector
6. Valid Points
 - 6.1 Point(s) shall be awarded when a permitted technique is delivered to the scoring areas of the trunk with a proper level of impact.
 - 6.2 Valid points shall be awarded as follows;

One (1) point for a valid kicking technique on trunk protector Three (3) points for a valid turning kick to the trunk protector
7. Prohibited acts and penalties

In the case of an unintentional attack to the head, "Kyong-go" shall be declared In the case of an intentional attack to the head "Gam-jeom" shall be declared
8. Decision of Superiority

In the case that there is still a tied score after completion a fourth (4) sudden death round the referee and judges shall take into consideration the level of disability in the decision of superiority
9. Sport class changes after first appearance
 - 9.1 Change to higher sport class

If an athlete's sports class changes to a higher sport class after the first appearance event, then it appears that the athlete's activity limitation was less severe than that of his/her competitors. This is an unfair advantage and the athlete's results in the initial sport class shall not be recognized. This includes change to sport class Not Eligible (NE)
 - 9.2 Change to lower sport class

If an athlete's sport class change to a lower sport class after the first appearance event, then the athlete's activity limitation appears more severe than that of his/her competitors. In this situation the athlete's competitors had an advantage in the event. As the athlete has been disadvantaged results and medals earned will be still be recognized and awarded.

10. WTF World Para-Taekwondo Championships will be organized based on the most recent Standing Procedure of the WTF World Para-Taekwondo Championships.

Paralympics will be organized based on the most recent Standing Procedure for Taekwondo Competition in the Paralympic Games

Article 23 Deaf-Taekwondo

This article outlines the modifications to the Competition Rules used for Deaf-Taekwondo. For matters not covered by Article 23 the WTF Competition Rules will apply.

1. Qualification of athlete
Contestant must have gone through classification procedures as outlined in the WTF Para-Taekwondo and DeafTaekwondo Classification Code and been assigned Sport Class and Sport Class Status
2. Weight Categories
Olympic weight categories apply to competitions in Deaf-Taekwondo
3. WTF World Deaf-Taekwondo Championships will be organized based on the most recent Standing Procedure of the WTF World Deaf-Taekwondo Championships.

Article 24 Sanctions

- 1 The WTF President, Secretary General, or Technical Delegate may request that on-spot Extraordinary Sanctions Committee be convened for deliberation when inappropriate behaviors are committed by a coach, a contestant, official, and/or any member of a Member National Association.
- 2 The Extraordinary Sanctions Committee shall deliberate the matter, and may summon person(s) concerned for confirmation of events.
- 3 The Extraordinary Sanctions Committee shall deliberate the matter and determine disciplinary actions to impose. The result of deliberation shall be immediately announced to the public and reported in writing, together with relevant facts and rationale to the WTF President and/or Secretary General.
 - 3.1 Potential violations on Conduct of a Contestant;
 - 3.1.1 Refusing the referee's command to complete the ending procedures of the match, including but not limited to bowing to his/her opponent at the end of the match or participating in the declaration of the winner.
 - 3.1.2 Throwing his/her belongings (headgear, groves, etc.) as an expression of dissatisfaction with decision.
 - 3.1.3 Not leaving the Competition area after the end of a match

- 3.1.4 Not returning to a match after a referee's repeated command
- 3.1.5 Not complying with the Competition Official's ruling or command
- 3.1.6 Manipulation of scoring equipment, sensors or/and any part of a PSS
- 3.1.7 Any serious unsportsmanlike behavior during a match or aggressive misconduct toward competition officials.
- 3.2 Potential violations on conduct of a Coach, Team Official, or other members of a Member National Association;
 - 3.2.1 Complaining about or/and arguing against an official's decision during or after a round.
 - 3.2.2 Arguing with the referee or other official(s)
 - 3.2.3 Violent behavior or remark toward officials, opponents or the opposing side, or spectators during a match
 - 3.2.4 Provoking spectators or spreading false rumor
 - 3.2.5 Instructing athlete(s) to participate in misconduct, such as remaining in the competition area after a match or to refuse bowing.
 - 3.2.6 Violent behaviors such as throwing or kicking personal belonging(s) or competition material(s).
 - 3.2.7 Not following instructions of competition officials to leave the Field of Play or Venue
 - 3.2.8 Any other serious misconducts toward competition officials
 - 3.2.9 Any attempt to bribe competition officials
- 4 Disciplinary actions:
Disciplinary Actions issued by the Extraordinary Sanction Committee may vary according to the degree of the violation. The following sanctions may be given:
 - 4.1 Disqualification of the athlete
 - 4.2 Warning and order to issue official apology
 - 4.3 Removal of Accreditation
 - 4.4 Ban from the Competition Venue
 - 1) Ban for the day
 - 2) Ban for the duration of the Championships.
 - 4.5 Cancellation of Result
 - i) Cancellation of the match result and all related merits
 - ii) Cancellation of WTF Ranking points

- 4.6 Suspension of athlete, coach, or/and team officials from all WTF activities (including CU and MNA level activities)
 - i) 6 months Suspension
 - ii) 1 year Suspension
 - iii) 2 years Suspension
 - iv) 3 years Suspension
 - v) 4 years Suspension
 - 4.7 Ban of MNA from participating in WTF Promoted or Sanctioned Championships
 - i) Specified championships
 - ii) All championships for a specified period of time (up to four (4) years)
 - 4.8 Monetary fine of between \$100-to-\$5,000 US dollars per violation.
- 5 The Extraordinary Sanctions Committee may recommend to the WTF that additional disciplinary actions be taken against the members involved, including but not limited to longer-term suspension, lifetime ban, and/or additional monetary fines.
 - 6 Appeal to the disciplinary action(s) taken by Extraordinary Sanctions Committee may be made in accordance with Article 6 if the WTF Bylaws of Dispute Resolution and Disciplinary Action.

Article 25 Other matters not specified in competition rules

- 1 In the case that any matters not specified in the Rules occur, they shall be dealt with as follows.
 - 1.1 Matters related to a contest shall be decided through consensus by the refereeing officials of the pertinent contest.
 - 1.2 Matters not related to a specific contest throughout the Championships such as technical matters, competition matters, etc shall be decided by the Technical Delegate.

(Referee's Hand Signals)

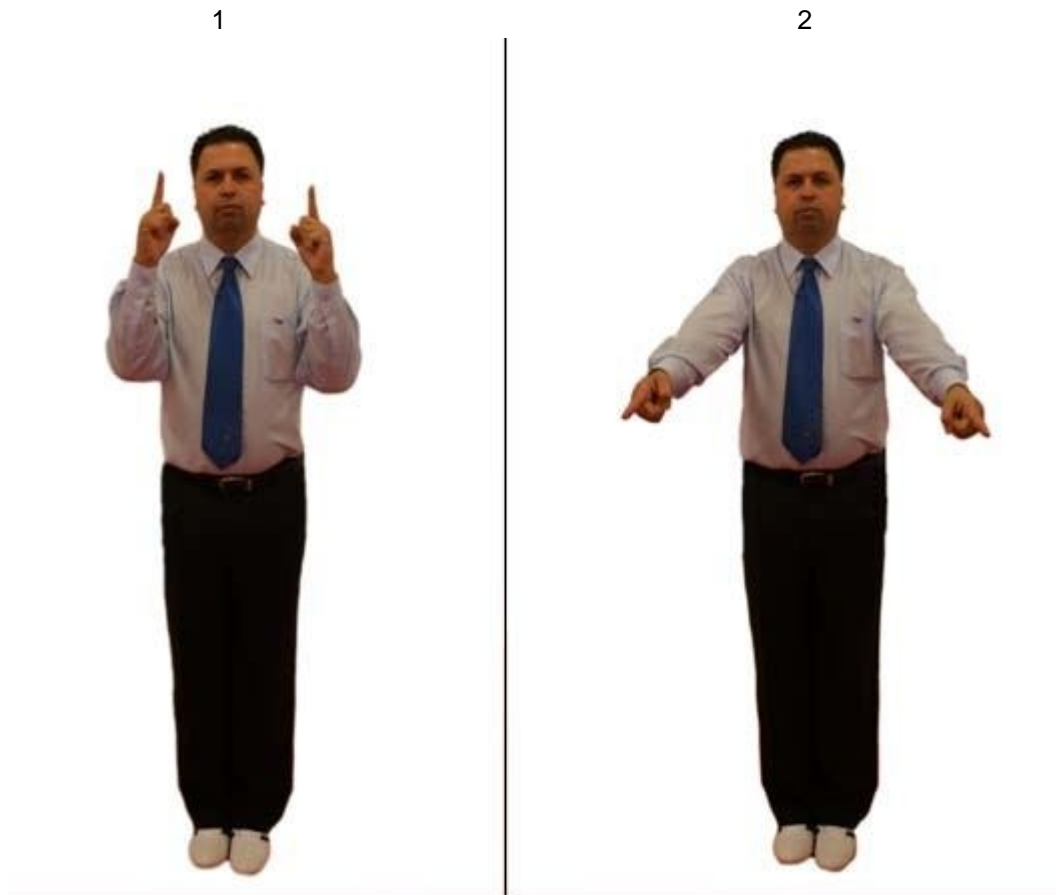

1. Call for contestants

- 1) Raise both clenched fists with the thumb placed on the middle finger and forefinger extended to the height of the ear.
- 2) Extend down the arms in turn, pointing to the “Chung” contestant’s mark with right forefinger and giving verbal command “Chung” then “Hong” contestant’s mark with left forefinger and giving verbal command “Hong”.

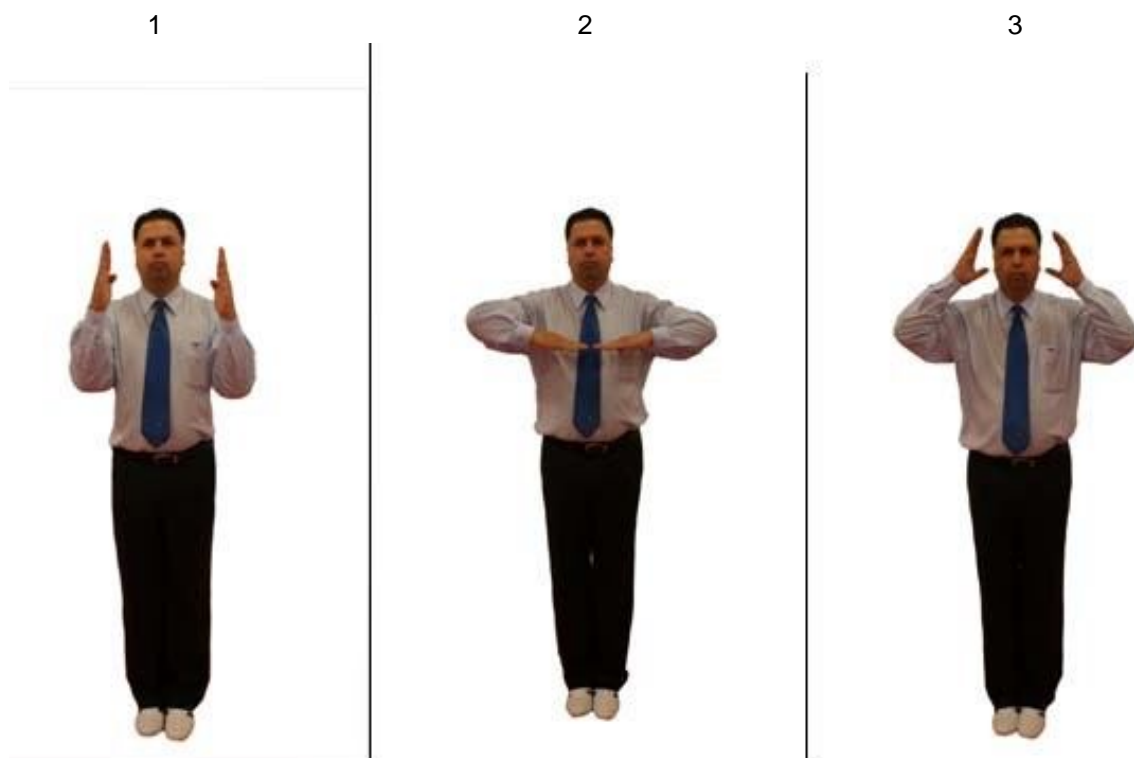

2. "Cha-ryeot" / "Kyeong-rye" / "Put on Head Protector"

- 1) Raise open palms facing each other with thumbs folded inward to the height of the eyebrows. Keep the arms apart from both sides of the trunk at 45 degrees, giving the verbal command "Cha-ryeot" and then,
- 2) Bring both hands to the front of the mid-point of the trunk, just beneath the breast bone, with palms down while giving a verbal command "Kyeong-rye". Keep a fist-sized distance between the fingertips of both hands and between hands and the trunk.
- 3) After verbal command of "Kyeong-rye", give the signal of "put on head protector" as follows; raise both arms bent at 45 degrees with open palms to the height of head.

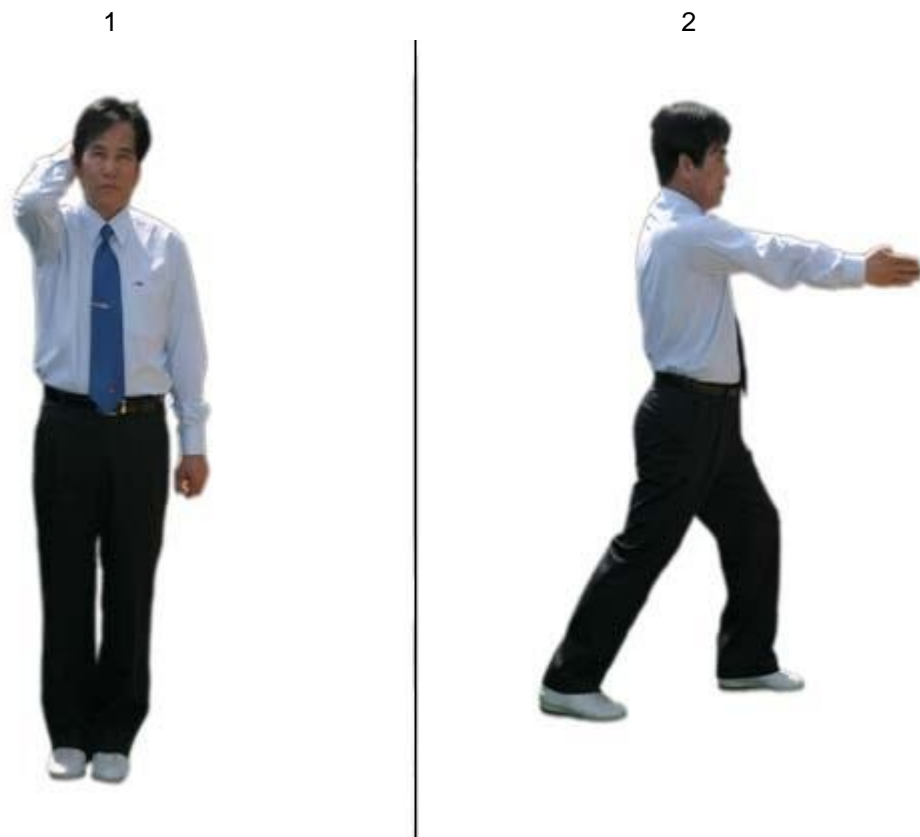

3. "Joon-bi"

- 1) Fold the right arm upward at 45 degrees until right hand is the same height as the right ear.
- 2) Extend the fingers of the right hand while extending the right arm fully down to the height of the mid-point of the trunk, just beneath the breast bone. In "Wen-Abgubi" stance (a step forward with the left leg), giving a verbal command "Joon-bi".

* While these actions are taken, put the left arm alongside the side of the trunk with the hand slightly clenched.

1



2



4. "Shi-jak"

- 1) Take "Bum-seogi" stance from the posture of "Joon-bi" by drawing back the left leg, opening both arms at 45 degrees from the shoulder with palms open.
- 2) Rapidly bring both arms before the breast with 25cm distance and with palms facing each other, giving a verbal command "Shi-jak".

(Front)



(Side)



5. "Kal-yeo" / "Keu-man"

Extend the right arm down with open palm to the mid-point of the trunk, just beneath the breast bone, taking "Wen-abseogi" stance can giving a verbal command "Kal-yeo" / "Keu-



6. "Kye-sok"

Take "Wen-abseogi" position, bend the right arm upwards until the forefingers are close to the right ear, giving a verbal command "kye-sok".

1



2



7. End of round

1) After the declaration of “Kal-yeo” / “Keu-man” at end of a round, raise both arms with clenched fists to the height of the mid-point of the trunk, just beneath the breast bone, then 2) extends right arm to “Chung” coach side and left arm to “Hong” coach side in 180 degrees with open palms facing each side, “Chung” and “Hong,” respectively.

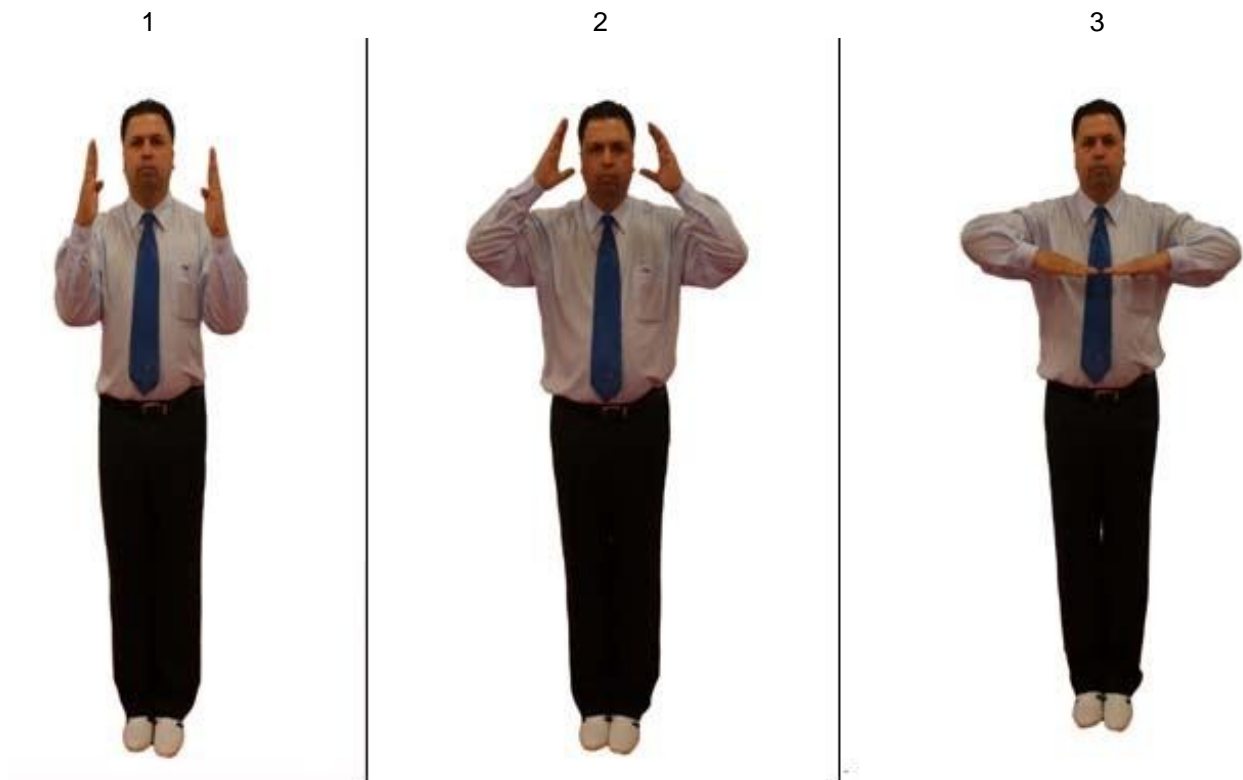

8. End of match

After declaration of “Kal-yeo” / “Keu-man” at end of a match, give the verbal command 1) “Cha-ryeot,” then 2) give signal of “take off head protector,” then 3) give the verbal command “Kyeong-rye”. The signals will be the same as (2. “Cha-ryeot” / “Kyeong-rye”/ “Put on Head Protector”)

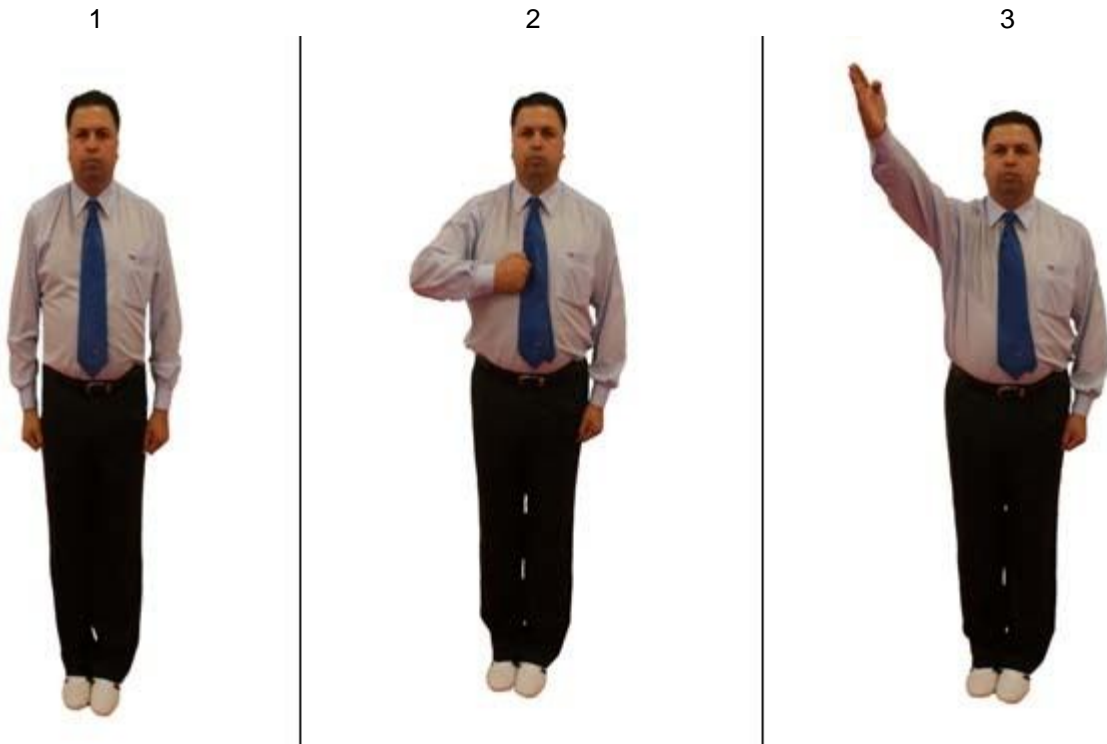

9. Winner declaration

- 1) In case the “Chung” contestant is the winner
- 2) Bring the clenched right fist to the mid-point of the trunk, just beneath the breast bone and then,
- 3) Extend the right arm up at 45 degrees with the open palm upward, declaring “Chung-seung”.

* While taking these actions, put the opposite arm alongside the side of the trunk with the fist slightly clenched.

* In case “Hong” contestant is the winner, follow the same procedure and declare “Hong-seung” using the left hand.



10. "Woo-se-girok"

In case of winner cannot be determined after a Golden Point round, 1) the center referee takes two steps back starting from left foot then right foot 2) put the left foot and the right foot together in "cha-ryeot" stance and give verbal command "Woose-girok".



11. "Kye-shi"

Extend the bended right arm down with the interior angle of the arm being 135 degrees, pointing at the Recorder's desk with the forefinger, giving verbal command "Kye-shi".



12. "Shi-gan"

Cross the forefingers of both hands with the left one outside just below the nose, pointing at the Recorder's desk with verbal command "Shi-gan".

1



1-1



13. Counting

Starting with the left arm relaxed, put the thumb of the right hand to the left shoulder. Count from "Hana" (1) through to "Daseot" (5) Extending the fingers one by one from the thumb of the right hand at one second intervals. Upon reaching "Daseot" (5) turn the open palm towards the pertinent contestant. Repeat the same procedure with the left hand starting with the thumb at the right shoulder and raising to a stand, counting "Ya-seot" (6) through to "Yeol" (10). Upon reaching "Yeol" (10), turn the open palm towards the pertinent contestant.

(Counting should be close to the pertinent contestants face to ensure the contestant can hear/see the count and the referee can check his/her condition.)

1



1-1



14. Calling for judges' gathering

In the case of one or more corner judges have raised their hand from the sitting position, the center referee shall call for a judges gathering. To signal a judges' gathering, extend out both arms with open palms to 135 degrees then bring in both arms to the height of the mid-point of the trunk, just beneath the breast bone.

1



2



15. Calling for the Commission of Doctor's aid

If the center referee has made a judgment that an athlete is in danger and needs the commission of a doctor's aid, then the center referee will immediately extend out and brings in his right arm to the height of the right ear and shout "Doctor, Doctor"

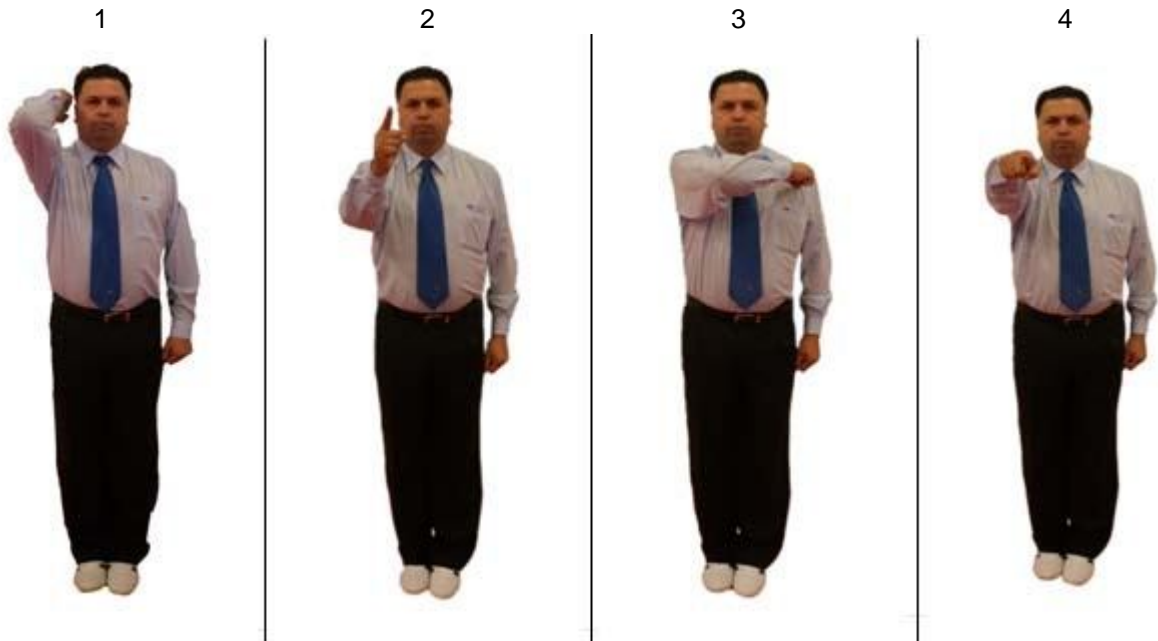

16. Declaration of "Kyong-go"

- 1) Start from the right ear with the right arm bent with clenched right fist and the forefinger extended.
- 2) Extend the right 45 degrees with the forefinger pointed at the pertinent contestant and giving verbal command "Chung" or "Hong".
- 3) Place the right arm bent with a clenched right fist on right chest.
- 4) Extend the right arm with the forefinger pointed forehead at the pertinent contestant and declaring "Kyong-go"

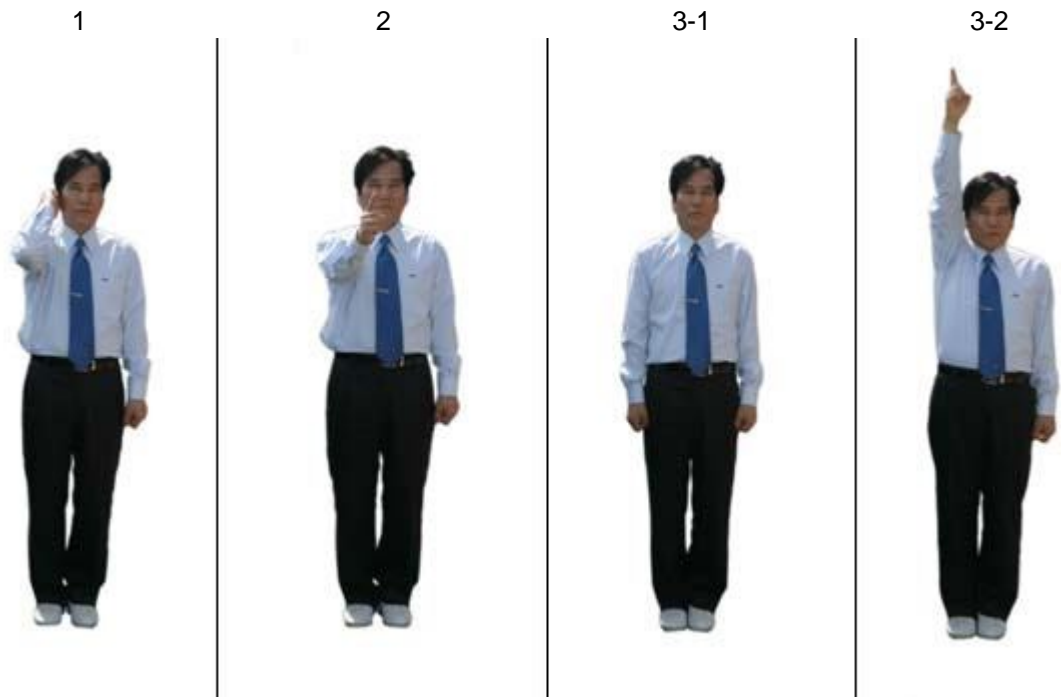

17. Declaration of "Gam-jeom"

- 1) Start from the right ear with the right arm bent with a clenched right fist and the forefinger extended.
- 2) Extend the right arm 45 degrees with the forefinger pointed at the pertinent contestant and giving verbal command "Chung" or "Hong".
- 3) In the "Cha-ryeot" stance, raise up the right fist vertically with the right forefinger stretched, declaring "Gam-jeom".

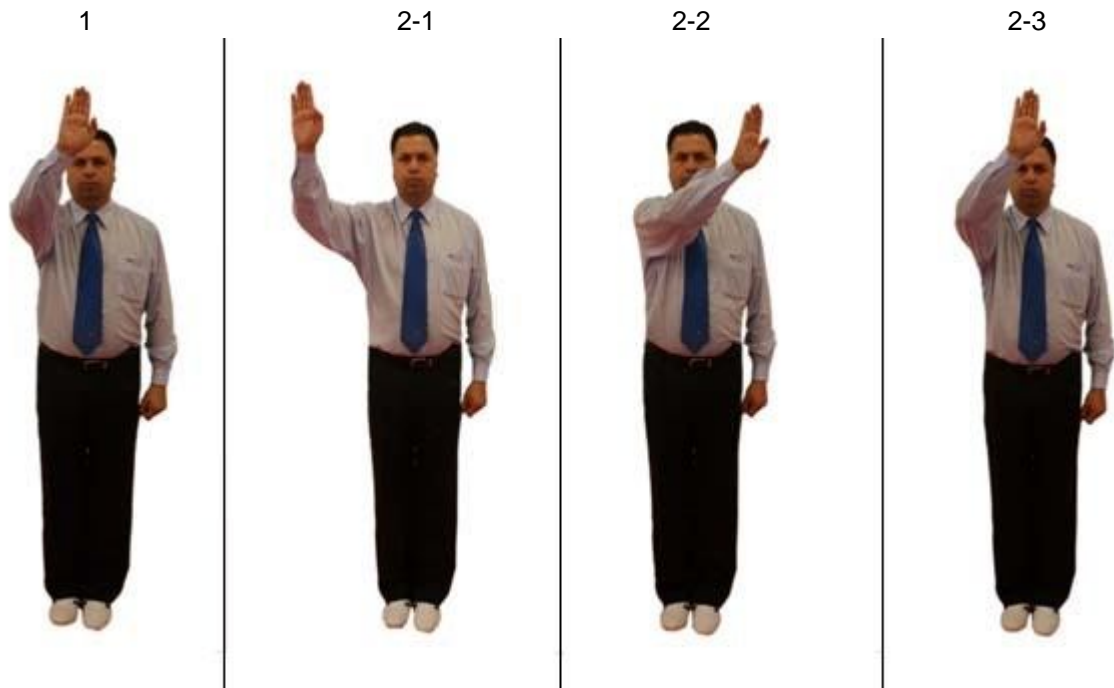

18. Invalidation of points scored

This is in regard to the article 12.5 of the Competition Rules that stipulates the invalidation of the points scored made immediately after the command “Kal-yeo”.

- 1) In the “Cha-ryeot” stance, raise the right palm before the forehead at a 20cm distance from the forehead.
- 2) Wave the right palm horizontally from right to left as widely as the shoulders and back to the starting position to invalidate the point(s) scored.

After the signal, as shown in picture 2-3, give the verbal commend “Shi-gan” to the Recorder’s desk and declare the penalty to the pertinent contestant. Time shall be started again from the point of the declaration “Kye-sok” after giving the penalty.



19. Declaration of instant video review request

At coach's request, the center referee shall declare an "instant video review request". Raise the right arm just above the head while holding a video review request card received from coach(s), then looking at the review jury's desk and give the verbal command "Chung" or "Hong" "Video Replay".

1-1



1-2



1-3



20. Declaration of points after instant video review

In the case of a point is granted after the video review, looking at recorder's desk, raise the right arm to the height of the head as shown in the pictures above, then give the verbal command "Chung" or "Hong" "Il-jeom", "Eui-jeom", "Sam-jeom".

1-1



1-2



1-3



1-4



1-5



21. Invalidation of points after instant video review

In case of a point is invalidated after the video review, looking at recorder's desk, give the verbal command "Chung" or "Hong" "Il-jeom", "Eui-jeom", "Sam-jeom" then following same procedure as (18. Invalidation of points scored).

1-1



1-2



1-3



1-4



22. Declaration of "Kyong-go" after instant video review

In the case of "Kyong-go" is granted after the video review, the center referee will follow same procedure as (16.Declaration of "Kyong-go").

1-1



1-2



1-3



1-4



1-5



1-6

23. Invalidation of "Kyong-go" after instant video review

In the case of "Kyong-go" is invalidated after the video review, looking at recorder's desk, gives the verbal command "Chung" or "Hong" "Kyong-go" followed by the same procedure as (18. Invalidation of points scored).

1-1



1-2



1-3



1-4

24. Declaration of "Gam-jeom" after instant video review

In the case of "Gam-jeom" is granted after the video review, the center referee will follow the same procedure as (17.Declaration of "Gam-jeom").

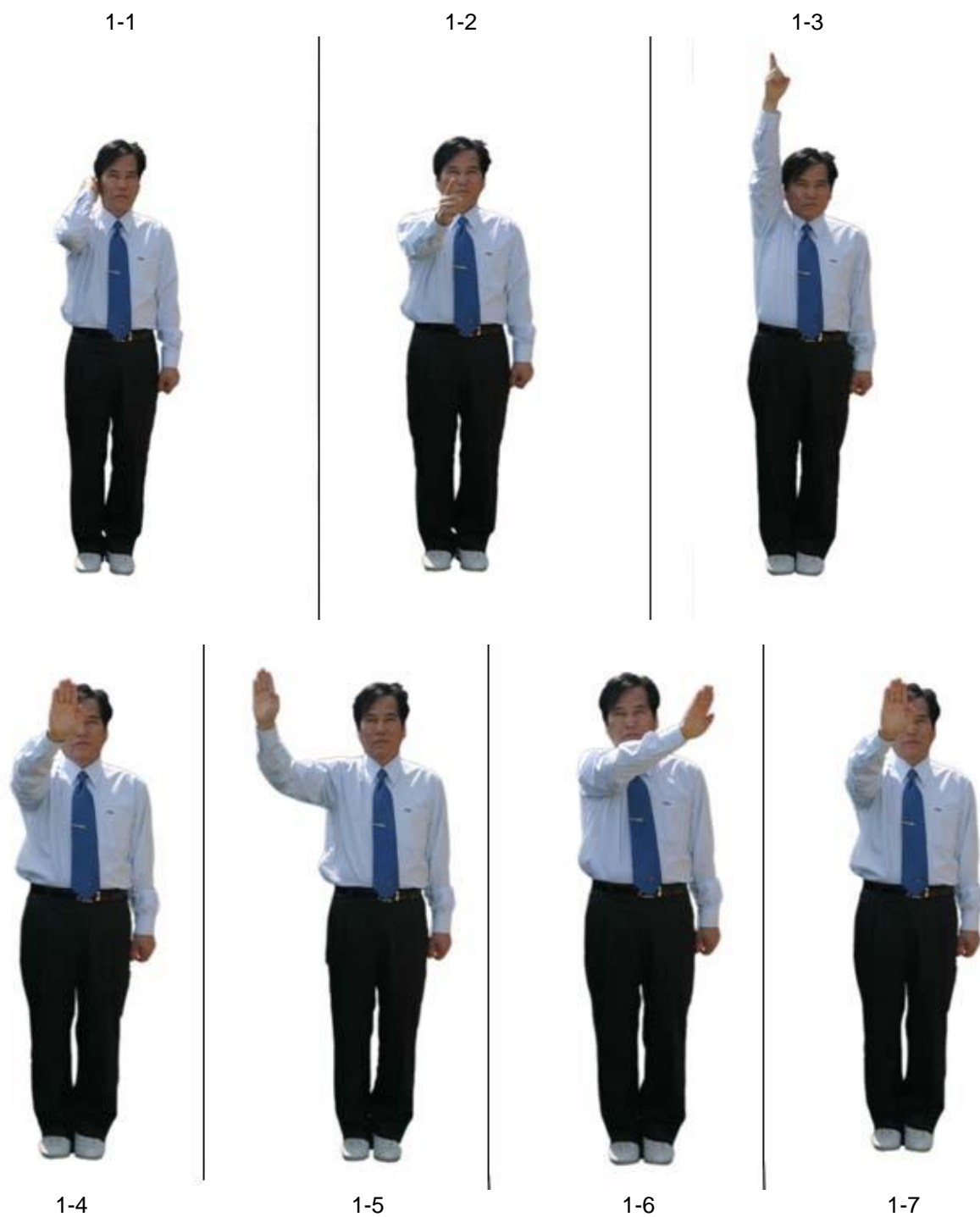

25. Invalidation of “Gam-jeom” after instant video review

In the case of “Gam-jeom” is invalidated after the video review, looking at recorder’s desk give the verbal command “Chung” or “Hong” “Gam-jeom-go” followed by the same procedure as (18. Invalidation of points scored).



26. Acceptance of reason of coach(s)'s request for instant video review

The center referee shall walk toward the coach's mark and return the video review request card to the coach politely.



27. Rejection of reason of coach(s)'s request for instant video review

The center referee shall return to the referee's mark and keep the video replay request card in shirt's pocket then resume the match.